



DEEP SEA ELECTRONICS

DSEA109 INSTALLATION INSTRUCTIONS

053-245
ISSUE 2

The DSEA109 is an Automatic Voltage Regulator (AVR) designed to control alternator excitation voltage to produce the desired alternator output. Adjustment is made using potentiometers. Alternatively more comprehensive configuration is available using DSE Configuration Suite PC Software and the DSE815 interface. Additionally this provides live diagnostic facilities.

NOTE: For the full specifications and mounting details, refer to DSE Publication: 057-295 DSEA109 Operator Manual, available from www.deepseaelectronics.com.

WARNING!: LIVE PARTS exist within the AVR. When powered avoid contact with components and terminals. Terminals remain live for up to 70 seconds after shutdown. Do not touch during this time. Only qualified personnel, having full understanding of the application must install the product.

POTENTIOMETER ADJUSTMENT

It is possible to disable the potentiometer using the DSE Configuration Suite PC Software and DSE815 Configuration Interface. This allows the system designer to restrict end user adjustment should this be required.

DIP SWITCH ADJUSTMENT

DIP switches are used to select the operating range of the AVR.

Function	DIP Switch 1		
Stability Configuration 1	Off		
Stability Configuration 2	On		

DIP Switches 2, 3 & 4 Functionality			
Function	DIP Switch 2	DIP Switch 3	DIP Switch 4
Main Configuration	Off	Off	Off
Alternative Configuration 1	Off	Off	On
Alternative Configuration 2	Off	On	Off
Alternative Configuration 3	Off	On	On
Alternative Configuration 4	On	Off	Off
Alternative Configuration 5	On	Off	On

LED STATUS

An LED shows operating status of the AVR.

LED State	Description
Off	Running, or stationary but powered by USB.
Rapid Continuous Flashing	Configuration file lost.
Single Flash	Start-up fail tripped.
Two Flashes	Over excite tripped.
Three Flashes	Loss of feedback tripped.
Four Flashes	Under frequency trip.
Five Flashes	Potentiometer fault.
Steady	UFRO / Idle Active

DIMENSIONS

Parameter	Description
Overall Size	180 mm x 145 mm x 61 mm (7.0 " x 5.7 " x 2.4 ")
Mounting Type	Screw Mounting to Chassis.
Mounting Holes	Suitable for M5 bolts/screws. Outside diameter 5.5 mm (0.2 ")
Mounting Hole Centres	150 mm x 120 mm (5.9 " x 4.7 ")
Mounting Orientation	Mount with potentiometers at the top.
Maximum Ambient Operating Temperature	-40 °C to 70 °C (-40 °F to 158 °F)

REQUIREMENTS FOR UL CERTIFICATION

Description	Specification
Conductors	<div style="border: 1px solid black; padding: 5px; margin-bottom: 5px;"> <p>⚠ CAUTION!: For applications in the US, the DSEA109 is rated as PD3 for 0 V to 430 V and PD2 for 430 V to 600 V. For applications in Canada, the DSEA109 is rated as PD3 for 0 V to 300 V and PD2 for 300 V to 600 V</p> </div> <ul style="list-style-type: none"> Use min 90 °C copper conductors only. Conductor protection must be provided in accordance with NFPA 70, Article 240 Low voltage circuits (35 V or less) must be supplied from the engine starting battery or an isolated secondary circuit. The communication, sensor, and/or battery derived circuit conductors shall be separated and secured to maintain at least 1/4" (6 mm) separation from the generator and mains connected circuit conductors unless all conductors are rated 600 V or greater.
Current Inputs	<ul style="list-style-type: none"> Must be connected through UL Listed or Recognized isolating current transformers with the secondary rating of 5 A max.
Communication Circuits	<div style="border: 1px solid black; padding: 5px; margin-bottom: 5px;"> <p>⚠ CAUTION!: The communication port is for temporary use and service access only by qualified service personnel only. Use appropriate Personal Protective Equipment (PPE) during connection as risk of potential shock hazard.</p> </div> <ul style="list-style-type: none"> Must be connected to communication circuits of UL Listed equipment.
Mounting	<ul style="list-style-type: none"> Suitable for flat surface mounting in Open Type Device Enclosure Type rating with surrounding air temperature -40 °F to +158 °F (-40 °C to +70 °C) Suitable for pollution degree 3 environments when voltage sensing inputs do not exceed 300 V. When used to monitor voltages over 300 V device to be installed in an unventilated or filtered ventilation enclosure to maintain a pollution degree 2 environment. Installed in accordance with the NEC (United States) and the CEC (Canada).
Operating Temperature	<ul style="list-style-type: none"> -40 °F to +158 °F (-40 °C to +70 °C)

TYPICAL WIRING DIAGRAM

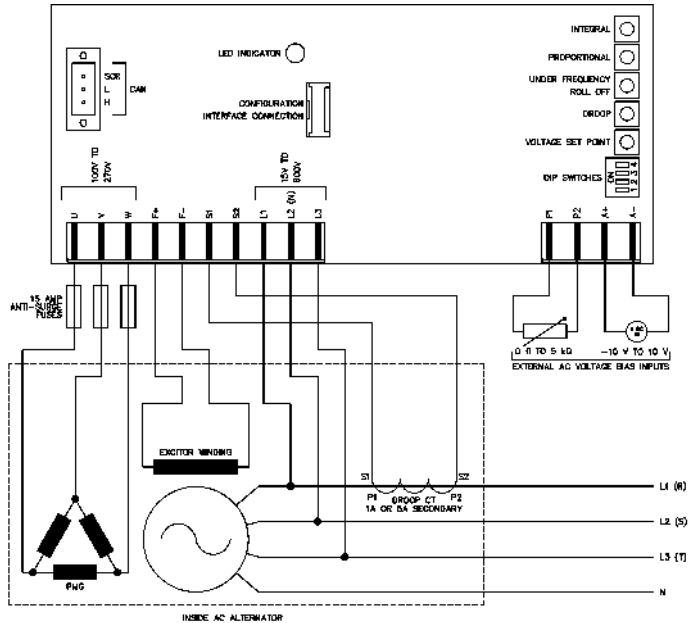

Deep Sea Electronics Ltd.

Tel: +44 (0)1723 890099

Email: support@deepseaelectronics.com

Web: www.deepseaelectronics.com

Deep Sea Electronics Inc.

Tel: +1 (815) 316-8706

Email: usasupport@deepseaelectronics.com

Web: www.deepseausa.com