

User Manual

EP600 ENERGY STORAGE SYSTEM

Shenzhen PowerOak Newener Co.,ltd

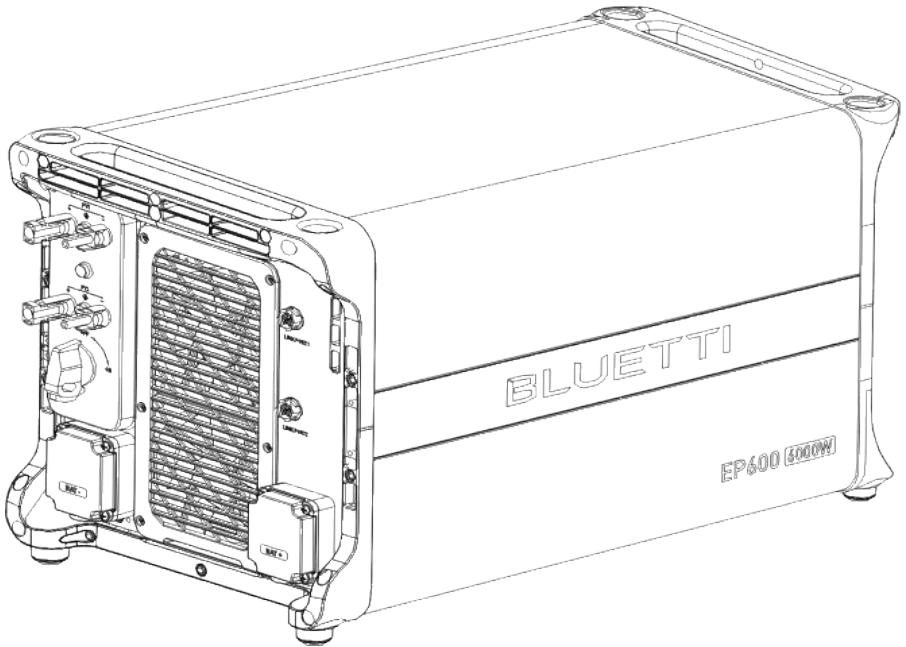



Thank You!

Thank you for making BLUETTI a part of your family.

From the very beginning, BLUETTI has tried to stay true to a sustainable future through green energy storage solutions for both indoor and outdoor use while delivering an exceptional eco-friendly experience for our homes and our world. That's why BLUETTI makes its presence in 70+ countries and is trusted by millions of customers across the globe.

Instruction

Copyright statement

The copyright of this manual belongs to Shenzhen PowerOak Newener Co.,Ltd without the written permission of the company, any company or individual is not allowed to extract or copy part or all of the contents of this manual, and shall not disseminate it in any way.

Attention

The products, services or features you purchase shall be subject to the commercial contracts and terms of our company. All or part of the products, services and features described in this manual may not be within the scope of your purchase. Unless otherwise agreed in the contract, this manual is only used as a guide, and the company makes no express or implied representations or warranties about the contents of this document. Shenzhen PowerOak Newener Co.,Ltd (hereinafter referred to as our company) reserves the right of final interpretation. Due to product version upgrade or other reasons, the contents of this manual will be updated from time to time. You can log in to our website: <http://www.poweroak.net> to check the latest version.

Summary

This user's manual introduces the installation, electrical connection, debugging, maintenance and troubleshooting of EP600 energy storage system, and the tutorial of user operation interface. When installing and using the system, please read the manual carefully, understand it's safety knowledge, and be familiar with it's functions and characteristics.

Reader

This guidebook is applicable to:

Professional technicians who need to install, operate and maintain the EP600 energy storage system.

User who learn to use BLUETTI APP for interface operation.

Conventional symbols

In order to ensure the personal and property safety of users when using the Energy Storage System and use the Energy Storage System more efficiently and optimally, the manual provides relevant information and highlights it with the following symbols. The symbols that may be used in this manual are listed below. Please read them carefully to better use this manual.

	Danger
	It indicates that there is a high potential danger, it may cause death or serious injury if not avoided.
	Warning
	It indicates that there is a moderate potential danger, it may cause death or serious injury if not avoided.
	Caution
	It indicates that there is a mild potential danger, it may cause moderate or mild injury if not avoided.
	Attention
	It indicates that there is potential risk. It may cause abnormal operation of the Energy Storage System or property loss if not avoided.
	Instruction
	The "Instructions" are not safety warning and do not involve information about personal, Energy Storage System and environmental injuries.

Content

1.1	Safety instruction	4
1.2	Precaution of installation	5
1.3	Precaution of electrical connection	6
1.4	Precaution of transportation	9
1.5	Box identification protection	10
1.6	Storage instruction	10
2.1	EP600 energy storage system instruction	11
2.2	Working mode	12
3.1	The function and character of EP600 inverter	14
3.2	Appearance instruction	14
3.3	LED Indicator	16
3.4	Buzzer Alarm	17
3.5	Routine maintenance	17
4.1	B500 Product Information	18
4.2	Appearance Description	18
4.3	Indicator Descriptions	20
4.4	Product Maintenance	21
5.1	EP600 Packing List	22
5.2	B500 Packing List	25
5.3	Base List	26
5.4	About installation	27
5.5	installation tools	30
5.6	installation steps	33
6.1	The whole units connection	35
6.2	B500 External ports description	37
6.3	Wiring description of EP600 external port	39
6.4	Connection ground protection (PE)	40
6.5	Connect PV cable	41
6.6	Connect the grid and load cable	44
6.7	Connecting the positive and negative poles of the battery	46
6.8	Other interfaces	48
6.9	B500 power on and power off	56
6.10	Communication methods	57
6.11	Firmware Upgrade	61
7.1	Preliminary Check	62
7.2	Power On	62
7.3	Power Off	62
8.1	Introduction	63
8.2	Download	63
8.3	Connection	64
9.1	Remove the Inverter	65
9.2	End-of-life Management for the Inverter	65
10	Troubleshooting	65
EP600	70
B500	73

1.SAFETY INSTRUCTION

1.1 Safety instruction

Please read the guidebook before using the equipment.

The technician responsible for installing must hold an electrician certificate, because some components might electric charged or heat up when the EP600 energy storage system running, improper operation,incorrectly install or operate might cause the serious damage of personal safety and property.



Don't place the equipment near the heat producer, it's forbidden to place or power on the Energy Storage System in the environment with flammable, explosive gas and smoke.

Except the authorized technician, please don't replace any components of Energy Storage System arbitrarily.There's no replaceable component in the package.

Please use the Energy Storage System in the well-ventilated environment, don't block the air vent of Energy Storage System, poor ventilate might cause the irreversible damage to the Energy Storage System.

Please don't place other object on the top of Energy Storage System when operating or settling.

Please don't move the Energy Storage System when it's operating, because the vibration and the shock produce from movement might cause the internal hardware failure.

	<p style="text-align: center;">Warning</p> <p>Please don't insert foreign object into any port of Energy Storage System. Please be aware of operating and keep children away from the Energy Storage System. If the Energy Storage System is on fire, please use dry powder extinguisher to put out the fire. For security, please use the cables configured by the original factory. We will not responsible for the equipment damage cause by the third-party device.</p>
	<p style="text-align: center;">Instruction</p> <p>The safety requirement of the guidebook aren't including the whole technical requirement but a supplementary instruction, the actual operation are contact with the on-site condition.</p>

1.2 Precaution of installation



Attention

Please attention, it's forbidden to power on EP600 energy storage system in the process of installation.

Please measure the voltage of contact point to make sure there's no risk of electric shock before touching any conduct's surface or metal terminal;

After the Energy Storage System is installed, please clean out the package material promptly, such as cartons, foam, plastics, nylon ties, etc;

Except the operator, please keep other people away from the Energy Storage System;

Please use original package or other material to packing the Energy Storage System for shockproof protection when moving;

All ports of the Energy Storage System must be sealed, and according the requirement to install the machine;

Forbid to alter ,damage or cover the identification and nameplate of Energy Storage System;

Please use the suitable tool to lock the screws tightly when installing the Energy Storage System;

Please fix the Energy Storage System on the group or other stable object(such as the wall or the frame) before operating;

Forbid to use water to clean the Energy Storage System or any electronic components;

Forbid to arbitrarily change or modify the structure、 the order of install, etc.

1.2.1 Requirement of installation and maintenance personnel

EP600 energy storage system installation、 electrical connection, test, maintenance, troubleshooting and replace operation must be operated by professional electrical technician. EP600.

The installation and maintenance personnel must have received professional

training, have clear knowledge about the Energy Storage System safety instruction and master the correct operation.

Professional personnel: Personnel who have received correspond technical training can clearly realize what risk may be brought to them during the operation, and able to take measure promptly to minimize the personal risk.

Energy Storage System or components (include software) must be replaced by professionals or authorized personnel.

1.2.2 Requirement of anti-static

When installing the cables, it is recommended to wear anti-static glove or anti-static bracelet before contacting the Energy Storage System. The other side of anti-static Bracelet should be grounded properly. Don't touch any exposed components directly with your hand.

1.2.3 Precaution of drilling

When drill on the wall or ground , the following safety protection measures should be considered;



Forbid to drill on the Energy Storage System. Drilling will damage the Energy Storage System's appearance, internal components and cable insulation. In addition, if metal debris enters the internal of Energy Storage System , it will cause internal circuit board short circuit;

Wear goggles and protective gloves when drilling;



In the process of drilling ,the power station should be covered and protected in case of the debris or dust drop into the power station.The debris and dust should be cleaned out promptly after drilling.

1.3 Precaution of electrical connection



The EP600 energy storage system will generate high voltage during operating, which may cause casualties, personal injury or serious damage to property. Please comply with relevant safety regulations during the installation、 trial run、 operation and maintenance of the product.

	<p style="text-align: center;">Danger</p>
	<p>Before connecting the power supply, make sure the Energy Storage System is not damaged, otherwise it may cause danger. Make sure the Energy Storage System and all relevant switches are in the "OFF" state, otherwise it may cause the electric shock.</p>
	<p style="text-align: center;">Warning</p>
	<p>All installation must only be operated by professionals or authorized personnel. The specification of cables which used for solar panel must proper, firm connection and good insulation. Incorrect wiring may damage the Energy Storage System , such resulting damage will not within the warranty.</p>
	<p style="text-align: center;">Attention</p>
	<p>The EP600 energy storage system can be grid-connected for power generation only with the permission of the electricity power department of the country or region.</p>

Precaution of operation

	<p style="text-align: center;">Danger</p>
	<p>When the Energy Storage System is running, please do not touch any terminal of the Energy Storage System, otherwise it may cause the electric shock. When the Energy Storage System is running, the shell temperature is high, please do not touch it, otherwise it may cause the burn injure.</p>
	<p style="text-align: center;">Attention</p>
	<p>In the process of moving the Energy Storage System, the weight of Energy Storage System shall be considered and take care of the balance to avoid the Energy Storage System overturn or fall.</p>







Precaution of repair and maintenance

	<p style="text-align: center;">Danger</p> <p>In the process of operating the Energy Storage System, there exist high voltage which may cause electric shock, result in the casualty or serious damage of personal injury and property. Therefore, the Energy Storage System must be shut down and powered off before operate any maintenance, and the precaution of safety which listed in this guidebook and other relevant documents must be strictly followed when operating the Energy Storage System.</p>
	<p style="text-align: center;">Danger</p> <p>Before operating any maintenance, the electrical connection between the Energy Storage System and the grid must be disconnected first, then disconnect the electrical connection between inverter and PV- battery pack. Wait for at least 30 minutes until the internal components are discharge completely then the maintenance can be operated.</p>
	<p style="text-align: center;">Attention</p> <p>In the process of maintenance, please observe the precaution of anti-static, wear anti-static gloves.</p> <p>If any maintenance is required, please contact the local authorized maintenance center. During the maintenance, please try to avoid irrelevant personnel from entering the maintenance site, temporary warning signs or fences must be erected for isolation.</p>

The label of Energy Storage System

There are some symbol related safety on the Energy Storage System's label . Please carefully read and fully understand the content of these labels before installing the Energy Storage System.

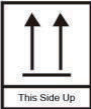
Figure 1-1 Safety label

Symbol	Symbol name	Symbol mean
	Delay discharge label	There still exist residual voltage after power off the Energy Storage System, it needs to wait for 30 minutes to ensure that the discharge is completed, then the maintenance can be operated.
	Anti electric shock warning symbol	This Energy Storage System has high voltage during operation. All operations of the Energy Storage System must be operated by trained professional electrical technician.
	Warning symbol	There are potential danger after the Energy Storage System is operated. Please take precautions during operation.
	Read instruction	Please read the instruction carefully before operate the Energy Storage System
	European standard CE certification	This product comply with European standard CE certification.
	This side up	It must always be transported, handled and stored in this way that the arrow always point upward.
	Weight symbol	The inverter and battery pack are pretty heavy and need to be moved by multi-people.

1.4 Precaution of transportation

When this product leaves the factory, it is in the best electrical and mechanical state. It's necessary to use the original package or appropriate package of the product to ensure the safety of the Energy Storage System during transportation.

The transportation company will be responsible for the machine damage caused during transportation. Please conduct a thorough check when picking up the products. If any packaging problems that may cause damage to the product or any visible damage of the product have been found, please notify the responsible transportation company immediately. If necessary, you can ask your installer or our company for help.

1.5 Box identification protection

The identification on the box contains important information for safe operation. It is forbidden to alter or damage it.

There's a nameplate on the side of the box, which contains important parameter information relate to the product. It is forbidden to alter or damage it.

The label shouldn't be covered, please clean up regularly. It should be always visible.

1.6 Storage instruction

If the EP600 energy storage system isn't put into use immediately, the storage shall meet the following requirements:

Please power off the Energy Storage System and charge it to 50-70% of capacity before storage;

In order to keep the battery healthy, please fully charge and discharge it every six months;

When using or storing, please make sure the ventilate are proper.

Please keep away from flammable and explosive object or gas. It is recommended to place them in a clean and dry environment.

It's strongly recommended to frequently clean the dust and debris outside the Energy Storage System with dry soft cloth.

Keep away from children and pet.

Please do not place anything on the top of the Energy Storage System when using or storing.

Avoid exposing to the equipment with rain, humidity or direct sunlight.

The details of storage temperature please view "11.basic parameter".

2. EP600 energy storage system

2.1 EP600 energy storage system instruction

The EP600 energy storage system include grid-connected inverter (EP600), energy storage battery pack (B500), IOT controller and other accessories (CT, cables, etc.), which can form a household energy storage and PV grid-connected power generation system with photovoltaic (PV) and user distribution box, etc; This system is suitable for families and regions with energy shortage or unstable power supply. The system has intelligent power generation and UPS function, and it can be operated and monitored by APP. It is simple operation, economical and practical.

The block diagram of EP600 energy storage system shown as below:

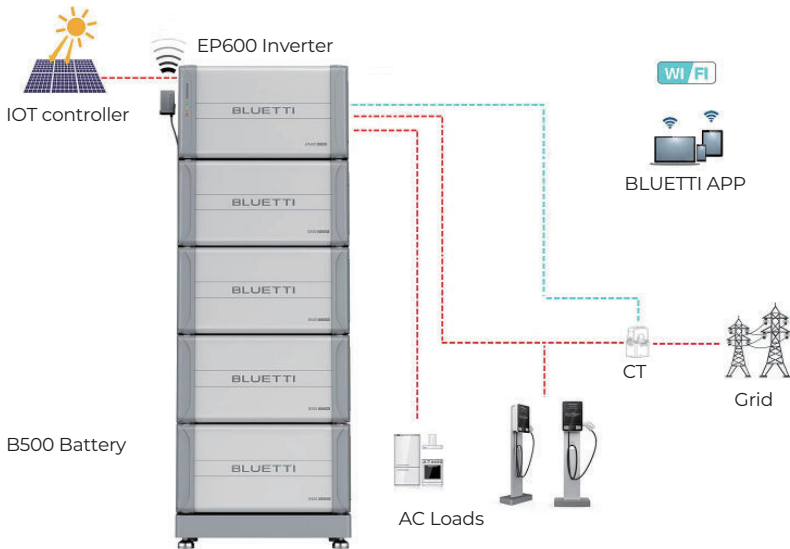



Figure 2-1 EP600 Energy storage system

	Instruction
	The introduction describes the general behavior of EP600 energy storage system, and the system operating mode can be adjusted on the APP of this product.

2.2 Working mode

The following are the general working modes of the EP600 energy storage system. According to your configuration and layout condition to select the working mode.

Mode 1

PV generate power to the load , the overflow power will charge the battery first, then output to the grid;

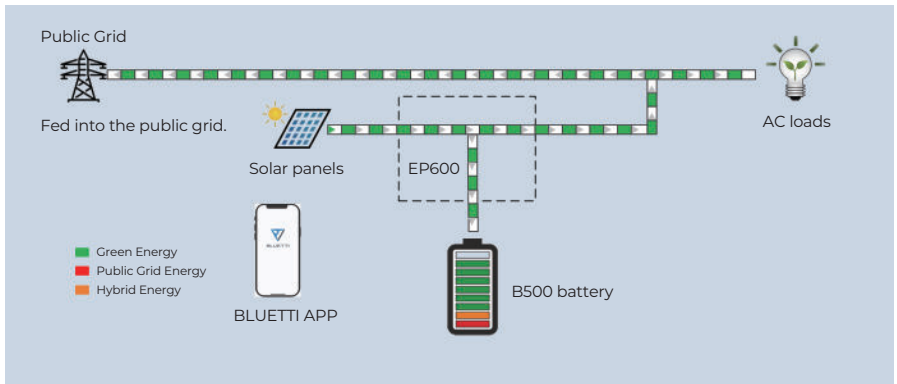

Figure 2-1

Mode 2

When there's no PV output , battery will provide power to the load first, then grid provide power when battery is in low power.

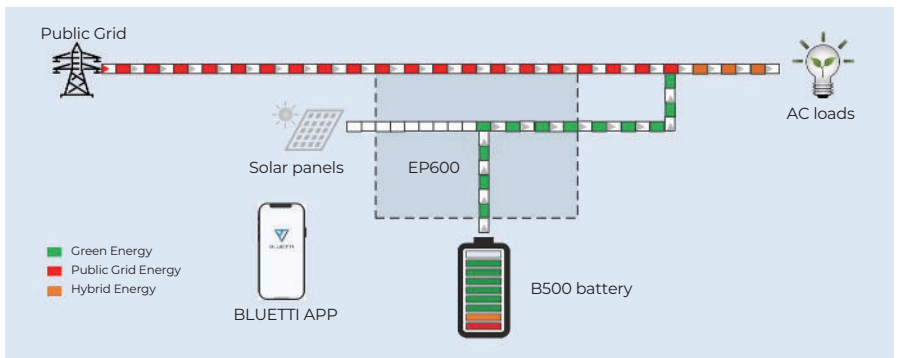

Figure 2-2

Mode 3

When the power grid is cut off, PV and battery will provide power to the load together.

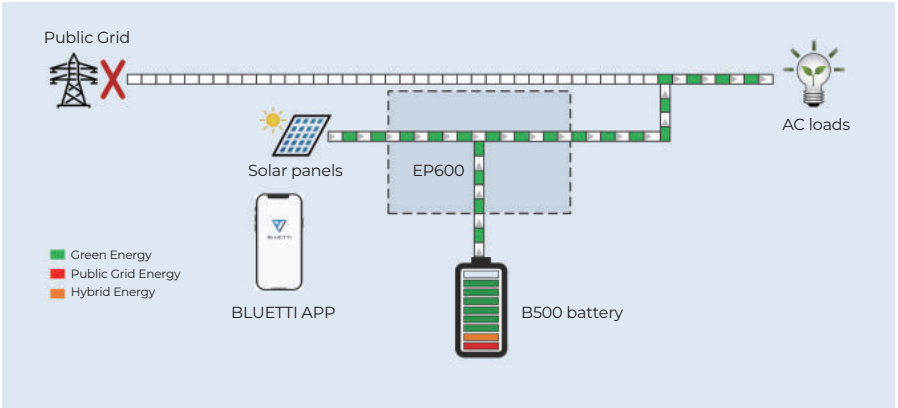

Figure 2-3

Mode 4

Battery can be charged by grid, the charging time and power can be set flexible in APP.

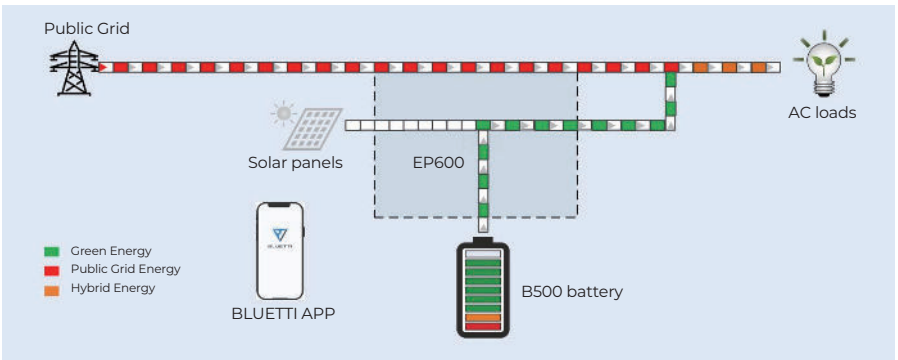

Figure 2-4

3. EP600 Inverter instruction

Ep600 inverter is a three-phase PV energy storage inverter integrate PV input and grid-connection charging and discharging. It is an important part of EP600 energy storage system.

3.1 The function and character of EP600 inverter

PV application: Dual MPPT, which can achieve PV charge and storage energy, and also can generate power with grid-connected system .

Energy storage application: Intelligent user application mode, which can automatically control the flow of system charging and discharging power or according the user demand to adjust the energy actively .

UPS application: Under the uninterruptible power supply (UPS) mode, the switching time of on-grid and off-grid is less than 10ms, and off-grid output can connect the unbalanced load.

Battery expansion: Support parallel with 2-16 battery packs (B500) to expand the total capacity.

Intelligent monitor: WiFi / Bluetooth, support using app to control and monitor, and check the system condition at anytime and anywhere.

High protection: The protection level of the system is IP65, which can be installed and used in great majority environments.

3.2 Appearance instruction

EP600 Inverter product appearance

Figure 3-1

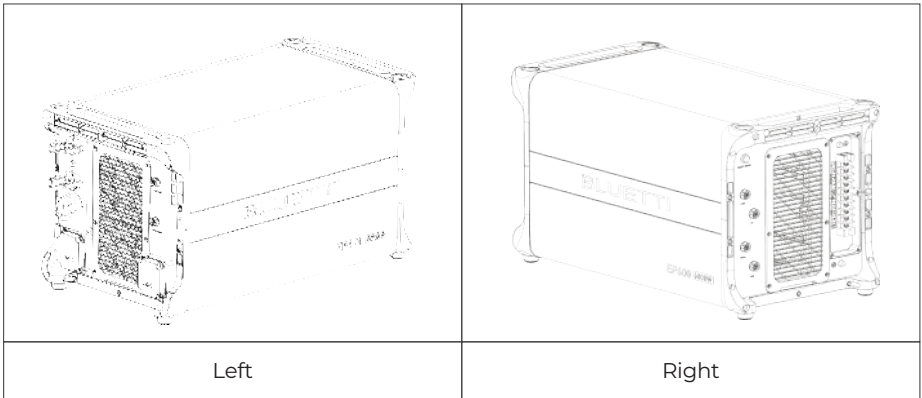

EP600 Inverter port description

Figure 3-2

Left		Right	
No.	Port name	No.	Port name
1	PV input 1	9	Waterproof and ventilate valve
2	PV input 2	10	COM Communicate Port
3	DC ON/OFF	11	CT Input Port
4	Battery Negative	12	DRMs Port
5	LED Indicator	13	USB Port
6	Signal Port 1	14	Load Port
7	Signal Port 2	15	Grid Port
8	Battery Positive	16	Ground

EP600 Inverter port description

Figure 3-3 (Unit: mm/in)

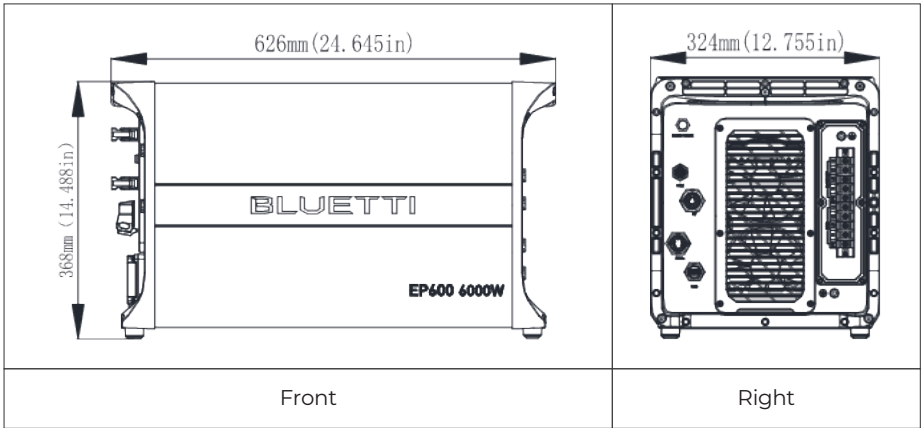

3.3 LED Indicator

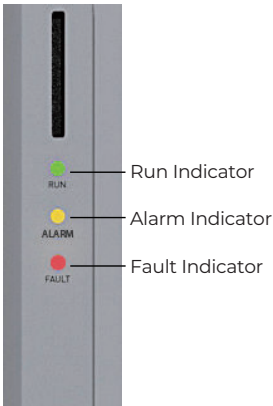

Figure 3-2

States	Run Green light	Alarm Orange light	Fault Red light
No alarm and No fault	Always ON	/	/
Alarm without fault	Flash	Always ON	/
No alarm with fault	/	/	Always ON
Alarm and fault	/	Always ON	Always ON

Table 3-4

3.4 Buzzer Alarm

When the buzzer setting is enabled :

When a new fault occurs, the buzzer sounds for 5s and stops for 1s. It will stop sounding after 10 cycles.

When a new alarm occurs, the buzzer sounds for 2s and stops for 1s. It will stop sounding after 10 cycles.

Fault Code	Content
5.	BUS overvoltage
7.	Battery overvoltage
8.	Inverter overcurrent
10.	LLC current overcurrent input

3.5 Routine maintenance

EP600 inverter requires regular maintenance, details shown as follow:

Check whether dust and other blockages are attached to the air outlet and the heat sink. If the fan is blocked or there is too much dust on the heat sink, clean the fan, fan guard or heat sink.

Check whether the fan makes abnormal noise when running.

Check whether the cable connection is loose or disconnected. Please use a torque wrench to tighten the AC and DC cable connections annually.

4.B500 Battery Pack Introduction

4.1 B500 Product Information

The B500 energy storage battery system is designed for residential and small commercial uses. Single pack rated capacity is 4.96KWh. It support 16 battery packs in parallel to meet capacity up to 80KWH.

The B500 battery management system adopts a multi-level architecture, which can detect the voltage, current and temperature of the battery pack in real time during the charging and discharging process. Accurately and efficiently realize the over-voltage, under-voltage, over-current, over-temperature and under-temperature protection of the system.

The safety function of B500 control system adopts redundant design, which meets the functional safety requirements and has good safety and stability.

4.2 Appearance Description

Appearance of B500 Battery Pack

Figure 4-1

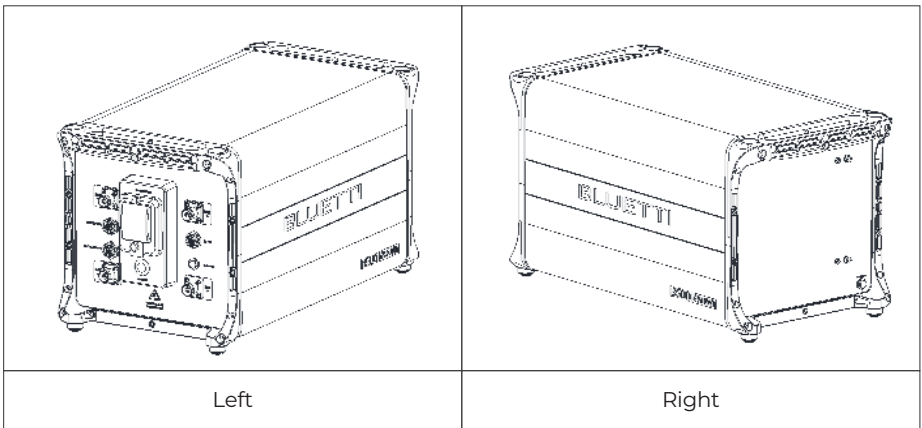

B500 Battery Pack Port Description

Figure 4-2

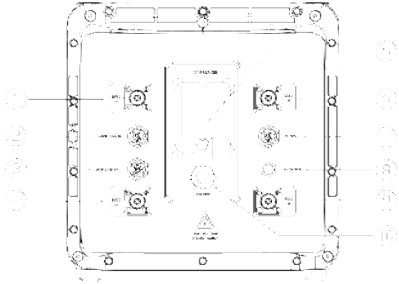
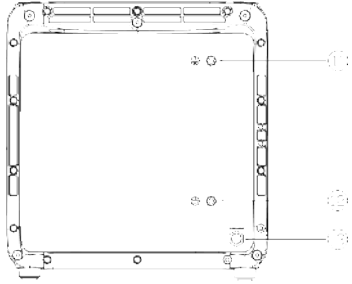
			
Left		Right	
No.	Port name	No.	Port name
1	Negative output cable port (Upper)	8	Waterproof and breathable valve
2	Signal connection cable port (Upper)	9	Positive output cable port (bottom)
3	Signal cable port (Bottom)	10	ON/OFF Switch
4	Negative output cable port (Bottom)	11	Ground wire port(Upper)
5	Manual mechanical switch	12	Ground wire port (Bottom)
6	Positive output cable port (upper)	13	Waterproof and breathable valve
7	Inverter signal cable port		

B500 Battery Pack Port Description

Figure 4-3 (Unit: mm/in)

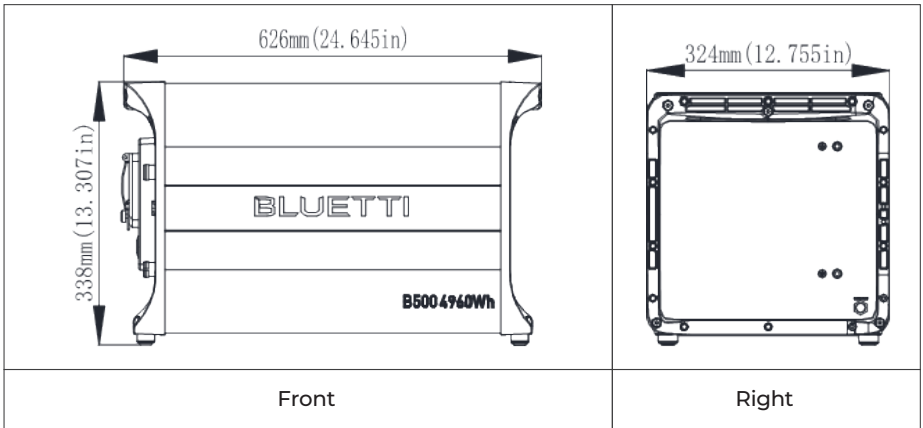

4.3 Indicator Descriptions

Light Status	Meaning	Remark
OFF	B500 not start	The circuit breaker can be operated now
ON	B500 is operating	The circuit breaker can't be operated now
0.5Hz Flash	B500 is shutting down	The circuit breaker can't be operated now
1Hz Flash	B500 is not operating	<p>If all B500 are flashing, it means that the B500 is temporarily unavailable and is restoring, please wait patiently. If it lasts for more than 1 hour, contact the authorized dealer or our company.</p> <p>If a single B500 flashes, it means the B500 is in fault status. Please contact the authorized dealer or our company immediately.</p>

4.4 Product Maintenance

If you find battery packs connected in parallel, and some of the battery pack indicators are off, please contact the authorized dealer or our company immediately.

If you find the B500 battery pack is in a faulty state, please contact the authorized dealer or our company immediately.



If you find the B500 battery pack is temporarily unable to work and is restoring, please wait patiently. If it lasts for more than 1 hour, contact the authorized dealer or our company immediately.

The circuit breaker automatically turns "OFF", which means the system is failure. The user are forbidden to operate currently, must be handled by the after-sales service, must contact the dealer or the manufacturer.









Do not disconnect the circuit breaker when the B500 battery pack is in normal service state. Otherwise it may cause the B500 battery pack abnormal work .

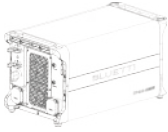



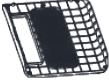



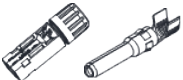

Do not remove the metal shell of the B500 battery pack under any circumstances. Otherwise, it may cause electric shock and explosion.







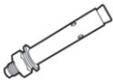



5. System Installation

	<p style="text-align: center;">Danger</p> <p>During installation, make sure that the product has no electrical connection. Do not install the Energy Storage System near pipes, windows or other similar areas where water can leak easily to prevent liquids from entering and damaging the Energy Storage System.</p>
	<p style="text-align: center;">Warning</p> <p>To prevent high temperatures and fires when the Energy Storage System is in operation, please do not block the ventilation area or radiation channel.</p>
	<p style="text-align: center;">Caution</p> <p>When transporting the inverter, please give priority to the weight of the inverter, and take care of the balance to avoid tipping or falling.</p>







5.1 EP600 Packing List



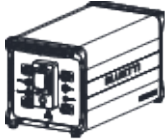

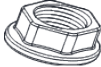
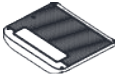
No.	Picture	Description	Quantity
1		EP600 inverter	1
2		Bracket No.1	2
3		Bracket No.2	2
4		M5 Hex Nut	2
5		PV decorative cover	1
6		AC decorative cover(With label)	1
7		Soft rubber stopper through the cable	2
8		AC cable protection box	1
9		1.PV+ Input terminal plastic case 2.PV+ Input terminal metal core	2
10		PV- Input terminal plastic case PV- Input terminal metal core	2

11		MC4 assemble and disassemble tool	2
12		BAT- Input terminal plastic cover(Black)	1
13		BAT+ Input terminal plastic cover(Red)	1
14		M4*12 screw (8 fix BAT+/- terminal cover. 6 AC junction Box)	14
15		M8*12 screw (Connect battery power cable)	2
16		M6*12 screw(Fix bracket-wall screw)	2
17		M5*10 screw (4 fixed bracket-machine, 2 PV ground)	6
18		M4*10 screw (Fix the decorative covers on both sides)	10
19		M8*60 Expansion bolt(Wall screw)	2
20		RNB3.5-5S TO terminal AC connection terminal *10PCS PV ground *2PCS	12
21		Battery power cable +	1

22		Battery power cable -	1
23		IOT Controller	1
24		Expandable rubber stopper	2
25		M3 tapping screws(KA3*25)	2
26		IOT Controller mounting bracket	1
27		DRMs port connection cable	1
28		CT port connection cable	1
29		M20-6PIN adapter	2
30		DRMs/CT adapter cable(1.5m)	2
31		CT	3
32		PG waterproof connector	2

5.2 B500 Packing List

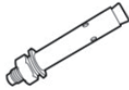
No.	Picture	Description	Quantity
1		B500 Battery Module	2
2		Bracket 1	2
3		Bracket 2	2
4		M5 Hex Nut	2
5		Left decorative cover	1
6		Right decorative cover	1
7		M4*8 screw	10
8		M5*10 screw	4
9		Battery positive expansion cable(Orange)	1

10		Battery negative expansion cable(Black)	1
11		Communication cable	1
12		Ground cable	1
13		M8*60 Expansion bolt(Wall screw)	2
14		M6*12 Ground cable screw	2
15		Spare screws	1

5.3 Base List

No.	Picture	Description	Quantity
1		Base	1

5.4 About installation

5.4.1 Installation Environment Requirements

- Choose a dry, tidy place for easy installation
- The protection level of the inverter and battery pack is IP65, and can be installed both indoors and outdoors.(If it is installed outdoors, additional protective measures are necessary to avoid direct sunlight)
- If the system is installed in direct sunlight, the performance of the system may be degraded as the temperature rises.
- During the operation of the inverter, the temperature of the body and heat sink will be relatively high. Do not install the inverter in an easily accessible location.
- No flammable and explosive substances can exist in the installation environment.
- Do not install where children can reach
- Do not install outdoors in coastal areas, which areas within 500 meters from the coast or affected by sea breezes. The sedimentation amount of salt spray varies relatively widely depending on the characteristics of seawater, sea breeze, precipitation, air humidity, topography and forest coverage in the adjacent sea areas.
- The system should be installed in a well-ventilated environment to ensure good heat dissipation.
- Do not install the system in low-lying area where water can easily accumulate. Otherwise the water may leak into the equipment and cause system failure.
- Ambient temperature range : -20 C ~ 40 C
- Relative humidity:5~95%(non-condensing)
- Maximum height:2000m

5.4.2 Installation carrier Requirements

Do not install the system on flammable building materials.

Please ensure the ground where you are installing is flat and firm, and can carry the weight of the installation system.

5.4.3 Installation Angle Requirements

The system is equipped with a base, the base is placed on a flat ground, and the system is installed by stacking in layers.

The system should be installed close to the wall, and both sides of each layer of equipment need to be fixed on the wall through brackets.

The system is installed perpendicular to the horizontal floor.

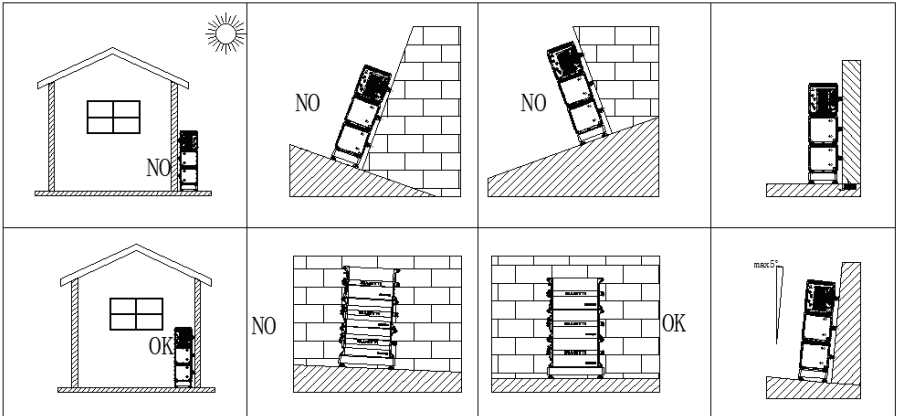

Picture 5-1

5.4.4 Space requirements for single system installation

The following diagram shows the EP600 system installed in a single group.

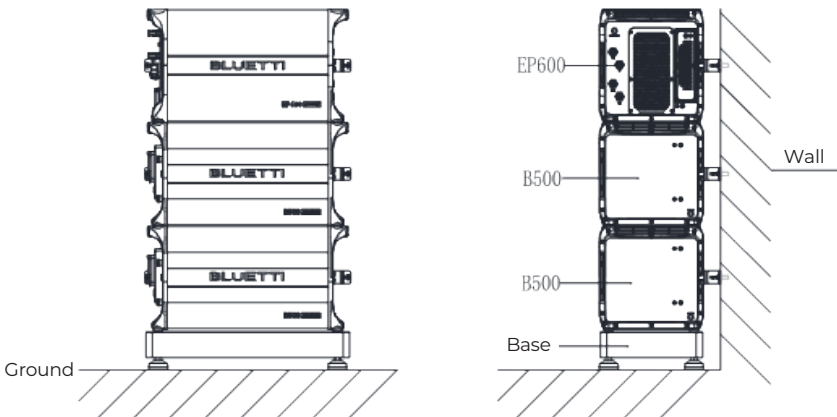

Figure 5-2 Ground, Base, Wall

5.4.5 Space requirements for multiple systems are installed side by side

When multiple systems are installed side by side, keep at least 1000mm distance between them to reduce the impact of heat dissipation.

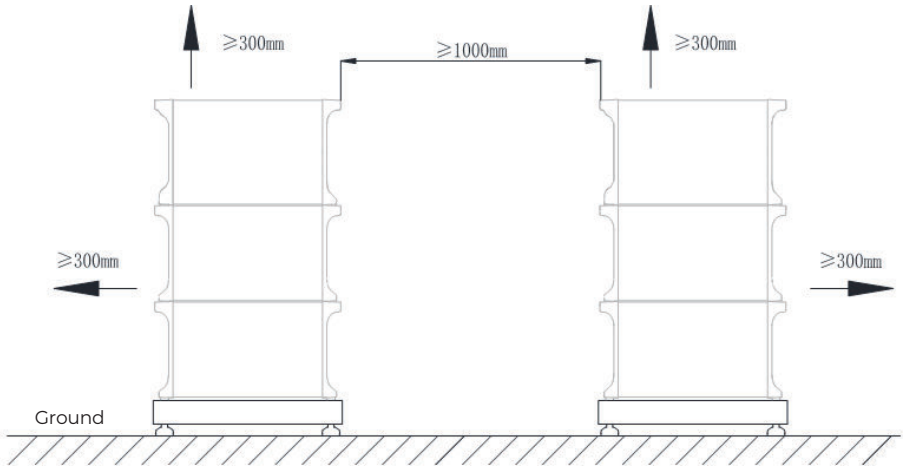

Table 5-3 ground

5.4.6 Size of base bracket installation

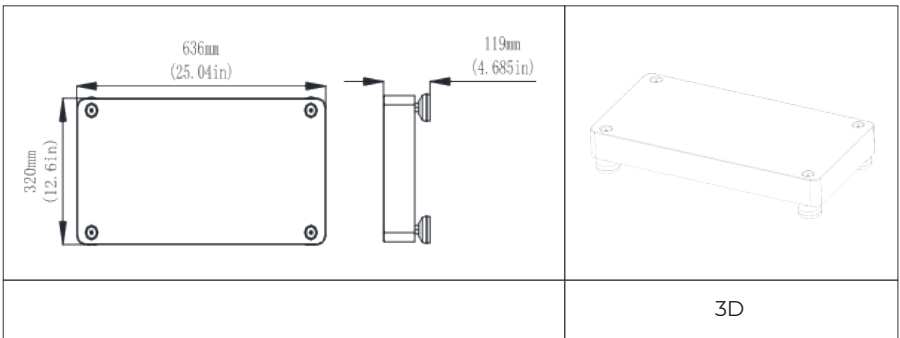

Figure 5-4

5.4.7 Installation

location requirements



Danger

Before drilling, please make sure to avoid the pre-buried water and electricity lines in the wall to avoid danger.

Project installation location

Size of drilling the wall mounting holes (unit: mm):

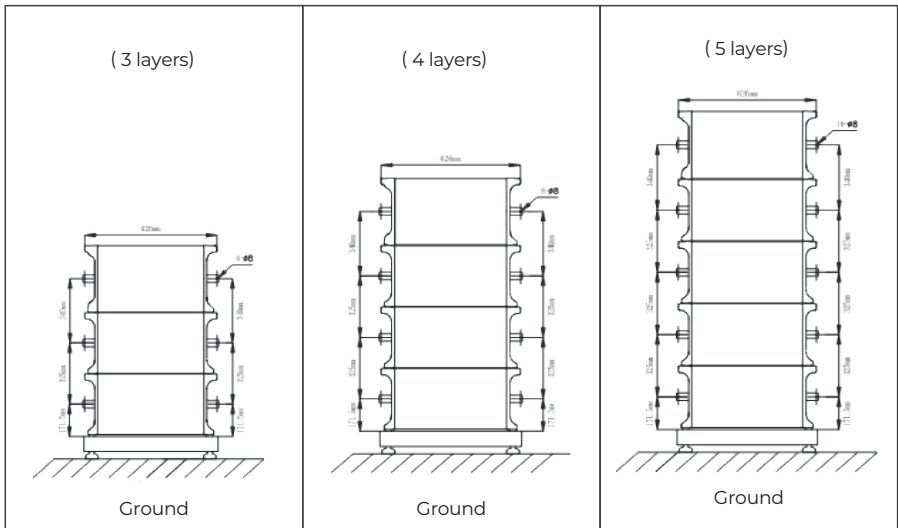

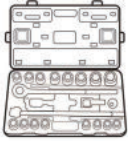





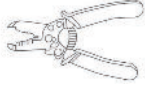











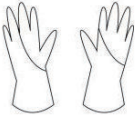



Figure 5-5

Remarks: For system installation, a maximum of 5 layers of Energy Storage System (include inverter) are stacked on the base. Each time a battery pack is added or removed, one group of mounting holes will be added or reduced accordingly, and the distance between adjacent battery packs is 325mm (combined with practical operations).

5.5 installation tools

Prepare the tools needed for installation and electrical connections.

No.	Tools Picture	Description	Function
1		Electric drill machine requires 8mm drill	Wall drilling
2		Torque socket wrench	Remove and install screws
3		Torque wrench	Remove and install screws
4		Flat screwdriver	Remove, install screws and cable
5		4mm cross screwdriver 4mm	Remove and install AC terminal screws
6		Removal tool	Remove PV Terminals
7		Cable cutters	Cut the cable
8		Cable stripper	stripping
9		Crimp tool	Crimp grid, critical load cable and CT extension cable
10		Multimeter (DC voltage range \geq 1000V DC)	Check whether the cable connection is correct, whether the positive and negative poles of the battery are correct, and whether the grounding is reliable

11		Marker pen	Punch mark
12		Measurement tape	Measuring distance
13		Level ruler	Make sure the base and backplane are level
14		Cutting knife	Cut
15		Thermal casing shrink tube	Tighten and insulate the cable
16		Heat gun	Tighten the heat shrink tube
17		Cable tie	Organize cables
18		Anti-static gloves	Wear it when carrying and installing the machine
19		Protective goggle	Wear while drilling
20		Face mask	wear while drilling
21		Safety shoes	Wear it when carrying and installing the Energy Storage System

22		Vacuum cleaner	Clean the site before and after installation
----	---	----------------	--

Table 5-4

5.6 installation steps

Step 1: Place the base on the ground of the installation position, adjust the height of the foot cup to make the base land stably. After the height of the foot cup is adjusted, tighten the nut so that the foot cup is not loose.



Step 2: According to the size of the installation location diagram of the project in Figure 5-5, use a measuring tape to find the drilling position, mark it with a marker, and then use an electric drill to drill the hole on the installation wall, and install the M8 expansion bolt.

Step 3: Hold the handles on two sides of the B500 battery pack by two people, lift it out of the box and carry it to the installation position, place it on the base, and place the four feet of the battery pack in the four grooves of the base.

Step 4: Take 2 mounting brackets No.1 and fix them on two sides of the battery pack with 4 M5X10 screws, then attach the mounting brackets No.2 through the expansion bolt and the pressure riveting screw of bracket No.1, and finally fix it with M8 and M5 nuts.

Step 5: Repeat Step3 and 4, and fix the subsequent battery packs in turn.

Step 6: Repeat Step3 and 4 to install the EP600 inverter on the top of the battery pack.

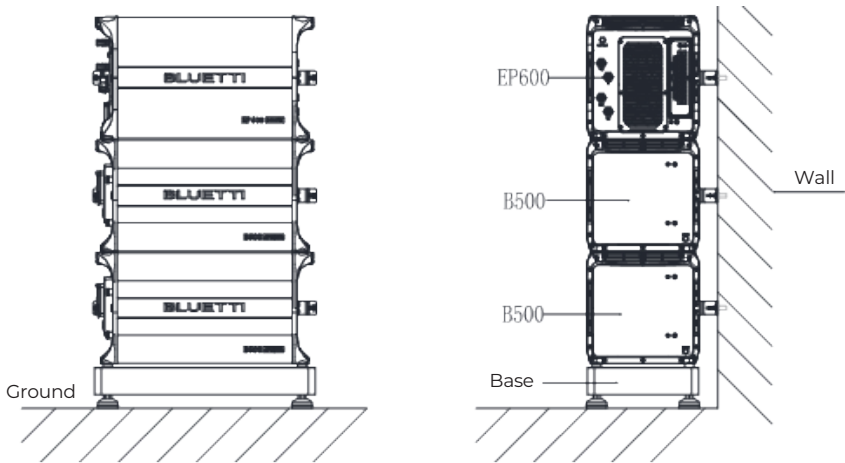



Figure 5-7

6. Electrical connection of EP600 energy storage system

Before installation and maintenance, make sure neither the AC side nor the DC side is electrified. For a period of time after the inverter is electrified and disconnected, the capacitor is still electrified, so it is necessary to wait treat 30 minutes to ensure that the capacitor is fully discharged. If it is not used as required, it may cause safety hazards.

	<p style="text-align: center;">Danger</p>
	<p style="text-align: center;">Warning</p> <p>All installation operations must be performed only by professional authorized personnel. The specification of cables used in the Energy Storage System must be proper, with strong connections and good insulation. Incorrect wiring may cause damage to the product, which will not within the warranty.</p>



	<p style="text-align: center;">Attention</p> <p>The installation and maintenance of the inverter must be operated by professional authorized personnel. Wear protective clothing (protective glasses and boots) when working in high-voltage or high-current systems (such as inverters and battery systems).</p>
	<p style="text-align: center;">Instruction</p> <p>The open circuit voltage of the PV modules connected to the EP600 cannot be more than 550V . The connected PV modules must have an IEC61730 class rating.</p>

Table 6-1 Current parameters

Model	IscPV (absolute maximum)	Maximum input overcurrent protection
EP600	15A/15A	15A/15A

6.1 The whole units connection



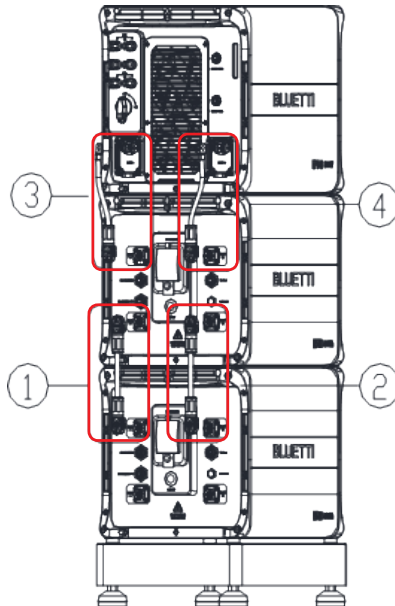
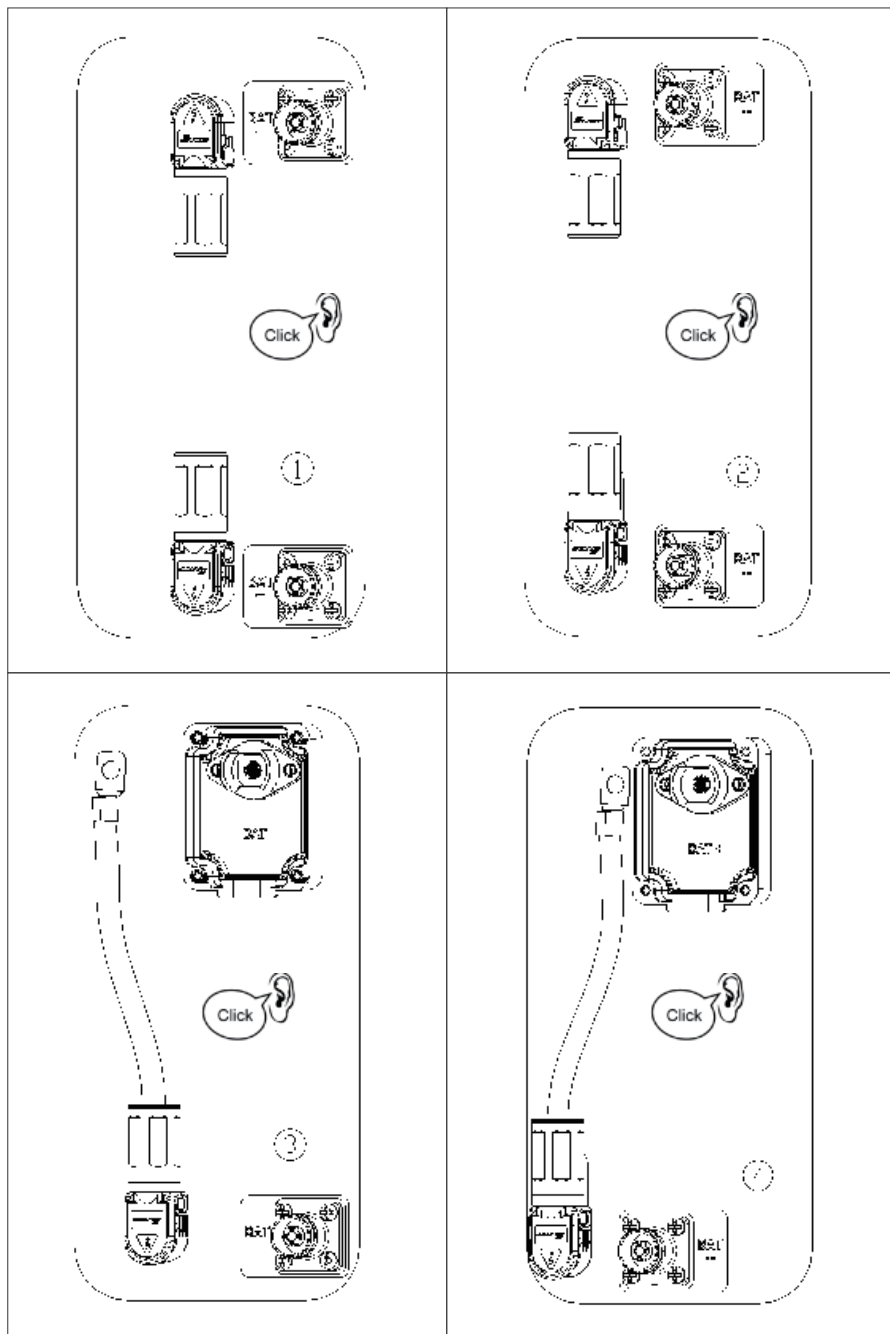

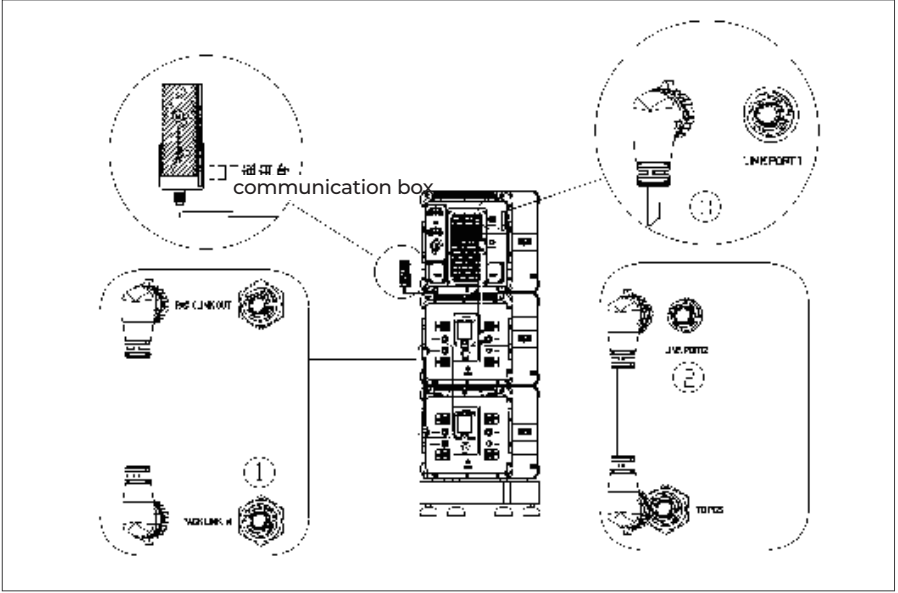
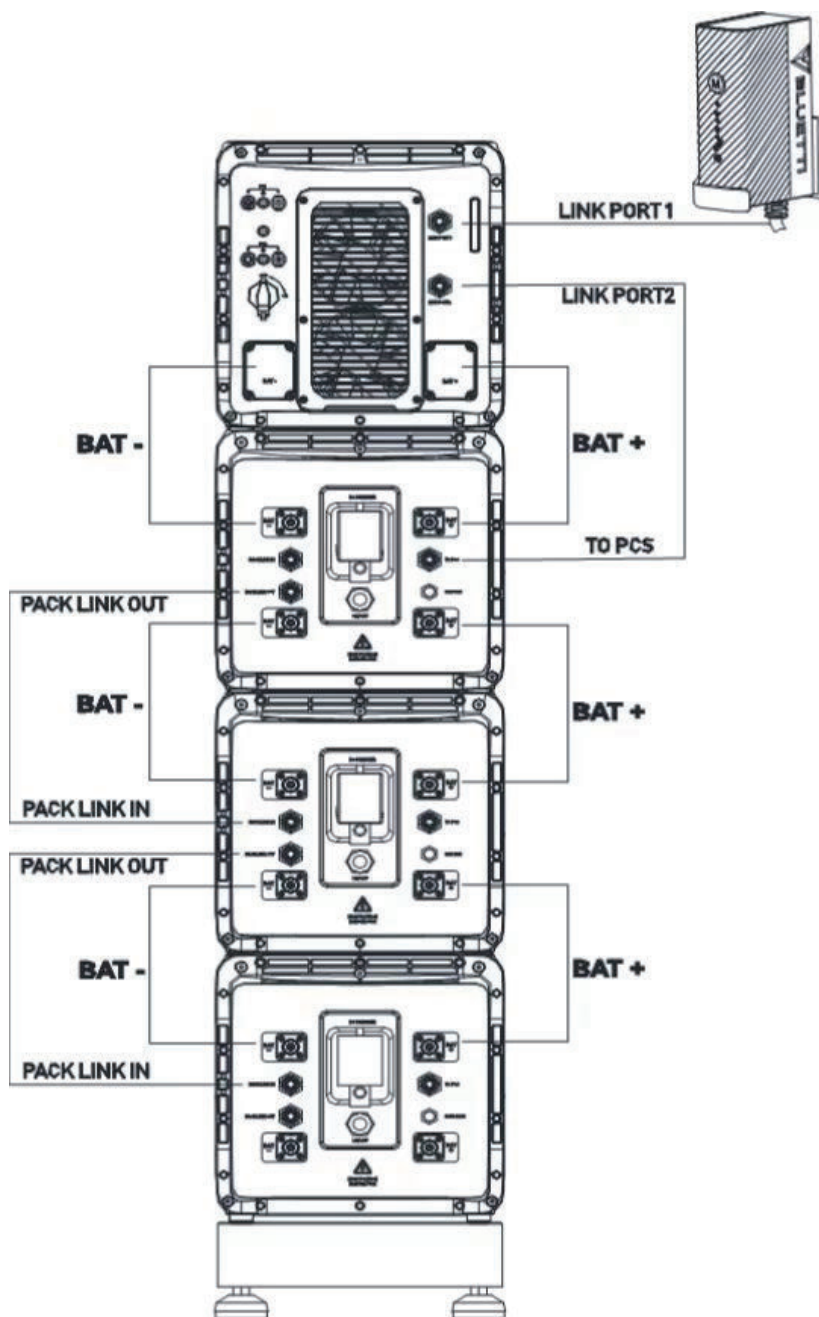

Figure 6-1

6.2 B500 External ports description

Connect port name	Connect port function	Remark
Inverter signal connect port (PCS Link)	Used to connect the inverter, only the top battery pack needs to connect inverter.	
Battery pack signal input port (PACK LinkIn)	When the battery is installed in a stack, it is used to connect the battery pack signal of the previous battery. The output port, such as the inverter above, is not connected.	
Battery pack signal output port (PACK LinkOut)	When the battery is installed in a stack, the battery pack signal used to connect the next battery, The input port, such as the battery pack is the bottom one, then do not connect.	
Positive output line port	Used to connect other batteries' Positive output line port or connecting to an inverter device BAT+ port.	Make sure it's plugged into place
Negative output line port	used to connect other batteries' Negative output line port or connecting to an inverter device BAT- port.	Make sure it's plugged into place

Table 6-2



6.3 Wiring description of EP600 external port

Figure 6-3 Cable instruction

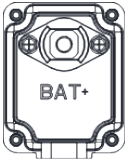
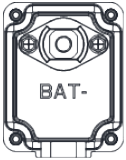
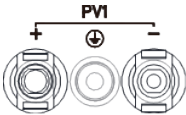
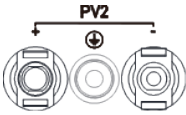
Port	Define	Cable type	Cable specification	
	BAT+: Wire the battery positive	Standard accessories		
	BAT-: Wire the battery negative	Standard accessories		
	PV1+: To solar panel positive PV1-: To solar panel negative PV1 PE: PV1 to solar panel ground	Outdoor multi-core copper core cable	Conductor cross-sectional area 2.5mm ² ~4mm ²	
	PV2+: To solar panel positive PV2-: To solar panel negative PV2 PE: PV2 to solar panel ground	Outdoor multi-core copper core cable		
	(GRID)	L1	Outdoor multi-core copper core cable	Cross sectional area of cable conductor 2.5mm ² ~ 4mm ²
		L2		
		L3		
		N		
		PE		
	(Load)	L1	Outdoor multi-core copper core cable	Cross sectional area of cable conductor 2.5mm ² ~ 4mm ²
		L2		
		L3		
		N		
		PE		

6.4 Connection ground protection (PE)

	<p style="text-align: center;">Danger</p> <p>The PV positive pole and negative pole of the inverter cannot be grounded, otherwise the inverter will fail. In EP600 energy storage system, all non-current carrying metal parts (such as bracket, distribution box, inverter shell, battery pack shell, etc.) should connect to the ground.</p>
--	---

Prerequisite: Prepare the ground cable (2.5mm² ~ 4mm² yellow green outdoor power cable and Rnb3.5-5s round bare terminal are recommended)

Step 1: Strip the insulation layer of the ground cable with a wire stripper to a proper length (as shown in Figure. 6-3-1).

Step 2: Thread the stripped insulation core into the conductor crimping area of OT terminal and press it tightly with crimping pliers (as shown in the figure 6-3-2).

Step 3: Fix the to terminal with M5 screws at the position shown in figure 6-3-3. The locking torque is recommended to be 3nm.

Note 1: L3 is the distance between the insulated terminal surface of the cable and the rear section of the terminal conductor crimping area, and L4 is the length of the conductor of the cable protruding from the terminal conductor crimping area.

Note 2: The cavity formed after the crimping of the conductor crimping piece of the terminal should completely cover the cable conductor, and the cable conductor and the terminal should be closely combined.

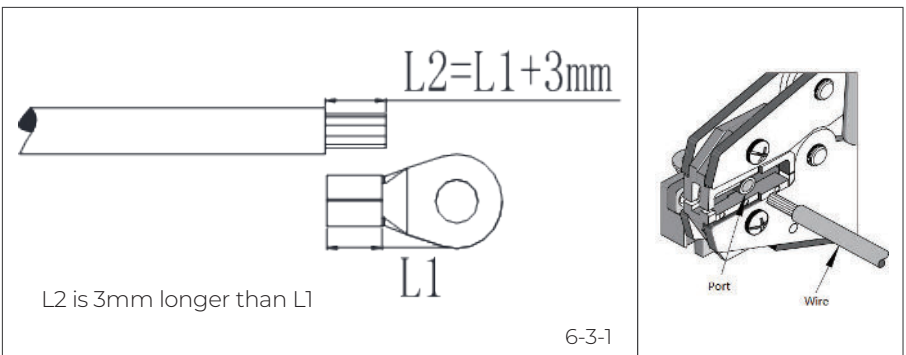

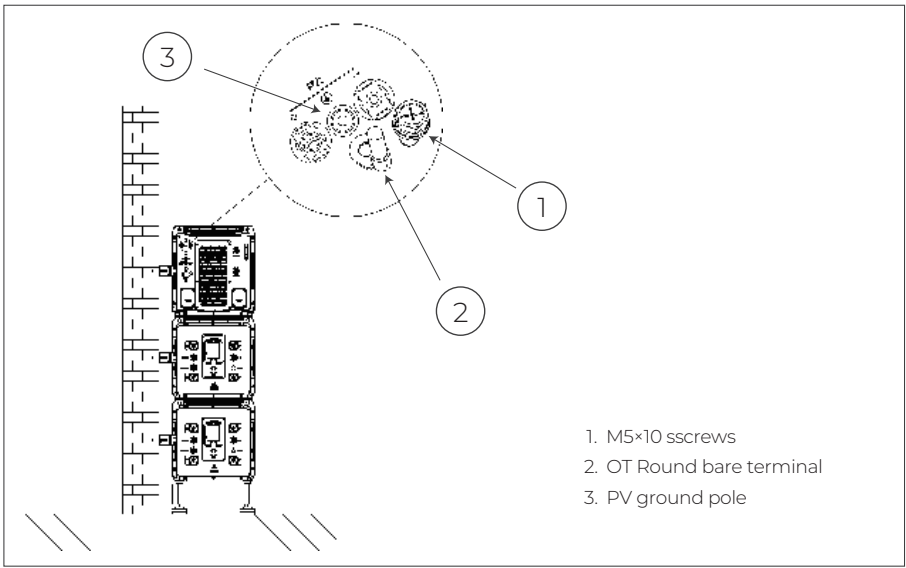
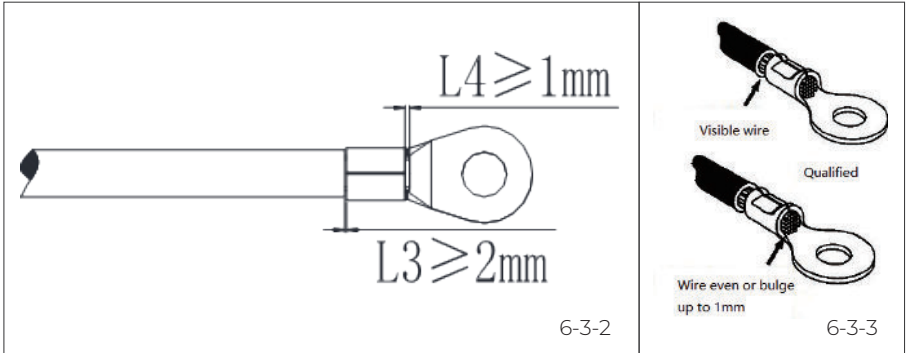

6.5 Connect PV cable

	Attention
	<p>Before removing the PV input positive and negative connectors, make sure the DC switch on the EP600 inverter has been set to "OFF".</p>

Step 1: Select the appropriate cable type and specification according to figure 6-3; Strip the cable, For the stripping length, refer to figure 6-5-1.

Step 2 : Insert the wire core with the insulation layer stripped into the conductor crimping area of OT terminal, and press it with crimping pliers(Figure 6-5-2).

Step 3 : Connect the cable with crimped terminals according to the electrical polarity of the load symbols marked on the junction box, and fasten with a screwdriver(6-5-3).

Step 4 : Connect the cable with crimped terminals according to the electrical polarity of the grid symbols marked on the junction box, and fasten with a screwdriver(Figure 6-5-4).

Step 5 : Put the PG waterproof connector into the AC protective cover of junction box , and tighten the hexagonal nut on the bottom of the PG waterproof connector with a socket tool(Figure 6-5-5).

Step 6 : Pass the cable through the PG waterproof connector , then fix the protective cover to the junction box with 6Pcs M4 screws. Tighten the screws with a cross screwdriver(Figure 6-5-6).

Step 7 : Tighten the nut outside the PG waterproof joint clockwise(Figure 6-5-7).

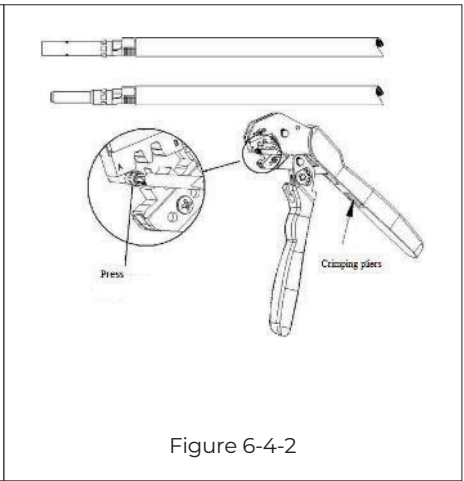
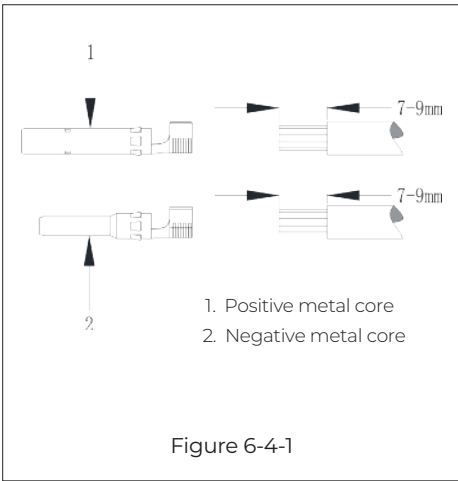

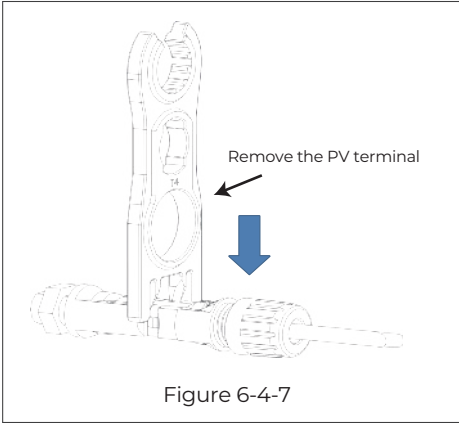
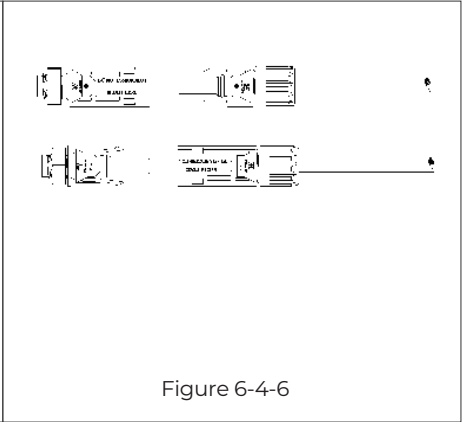
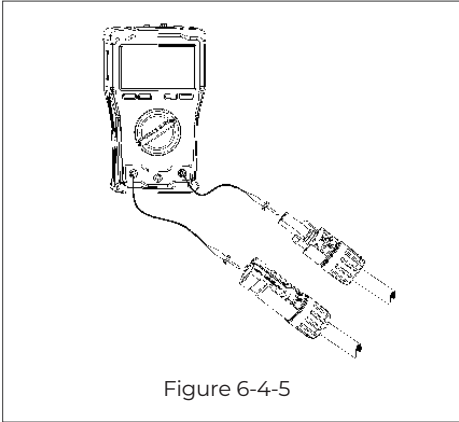
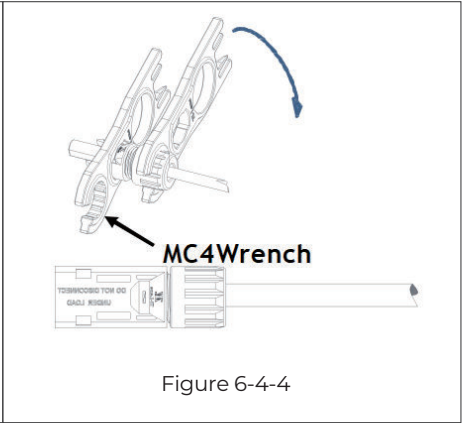
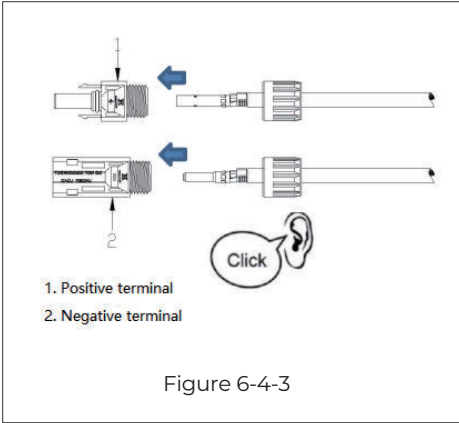

6.6 Connect the grid and load cable

Step 1: Select the appropriate cable type and specification according to figure 6-3; Strip the cable, For the stripping length, refer to figure 6-5-1.

Step 2: Insert the wire core with the insulation layer stripped into the conductor crimping area of OT terminal, and press it with crimping pliers(Figure 6-5-2).

Step 3: Connect the cable with crimped terminals according to the electrical polarity of the load symbols marked on the junction box, and fasten with a screwdriver(6-5-3).

Step 4: Connect the cable with crimped terminals according to the electrical polarity of the grid symbols marked on the junction box, and fasten with a screwdriver(Figure 6-5-4).

Step 5: Put the PG waterproof connector into the AC protective cover of junction box , and tighten the hexagonal nut on the bottom of the PG waterproof connector with a socket tool(Figure 6-5-5).

Step 6: Pass the cable through the PG waterproof connector , then fix the protective cover to the junction box with 6Pcs M4 screws. Tighten the screws with a cross screwdriver(Figure 6-5-6).

Step 7: Tighten the nut outside the PG waterproof joint clockwise(Figure 6-5-7).

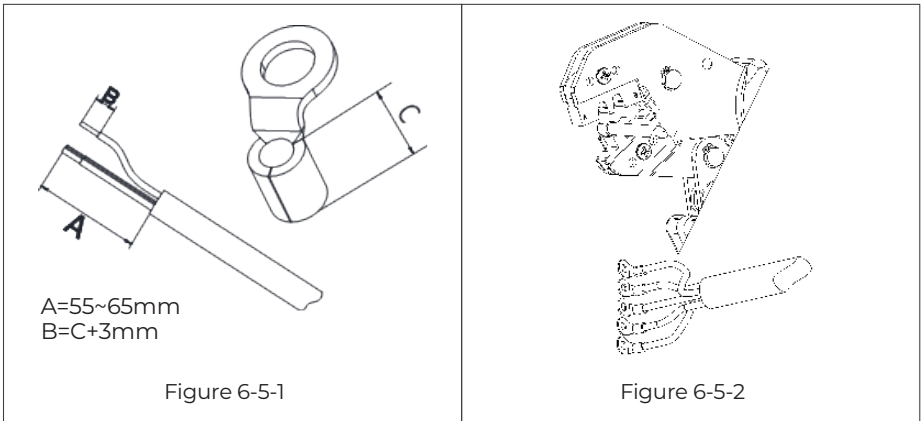

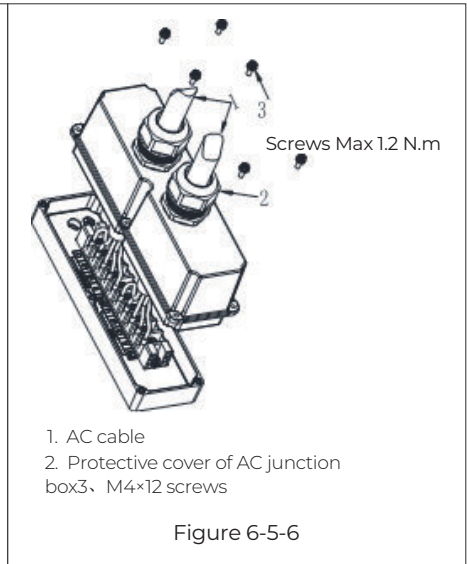
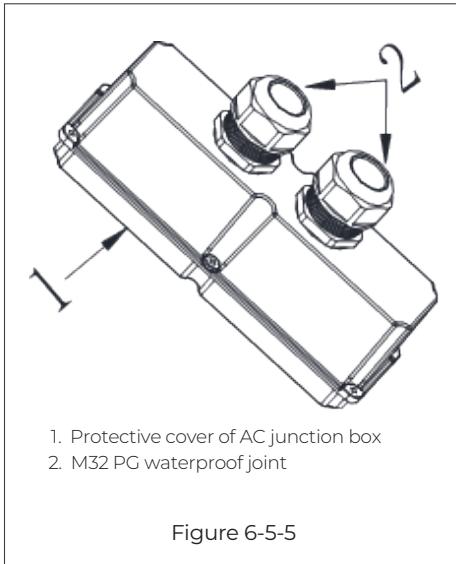
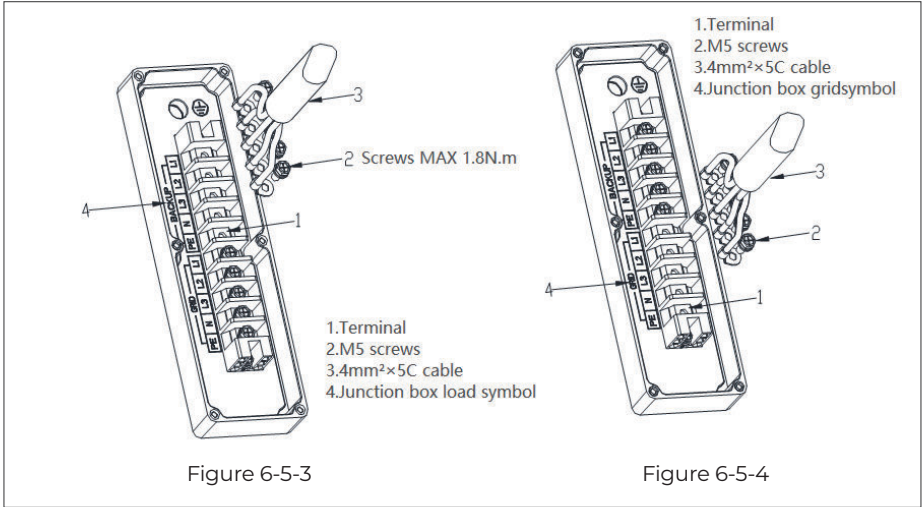

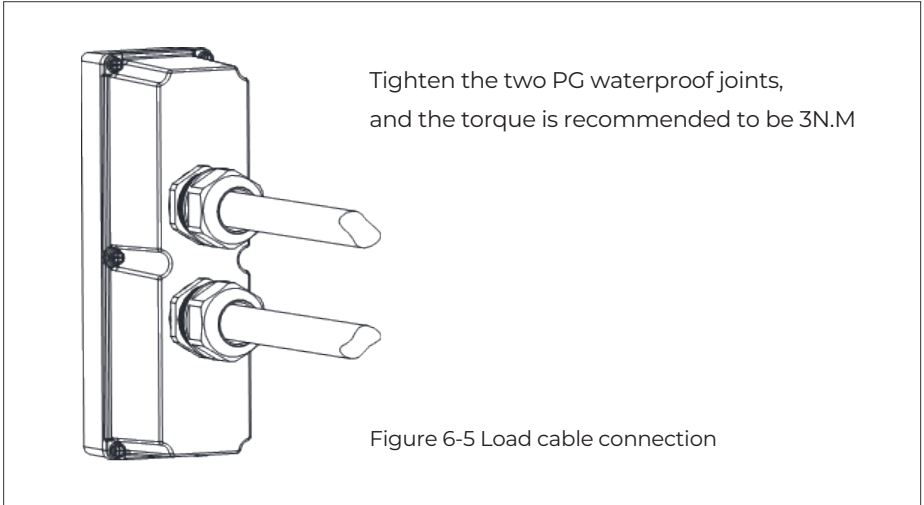

6.7 Connecting the positive and negative poles of the battery

Step 1 : Remove the positive and negative protective cover of the inverter battery with a screwdriver(Figure 6-6-1/6-6-2);

Step 2 : Connect the negative battery cable to the terminal of the negative junction box, and fasten the M8 screw with a screwdriver or sleeve. The recommended tightening torque is 8N.m. Then put the negative protective cover into the negative terminal box, and fasten the M4 screw with a screwdriver. The recommended tightening torque is 2N.m(Figure 6-6-3);

Step 3 : Connect the positive battery cable to the terminal of the positive junction box, and fasten the M8 screw with a screwdriver or a sleeve. The recommended tightening torque is 8N.m. Then put the negative protective cover into the negative terminal box, and fasten the 4 M4 screws with a screwdriver. The recommended tightening torque is 2N.m(Figure 6-6-4).

Step 4 : Connect the battery packs.

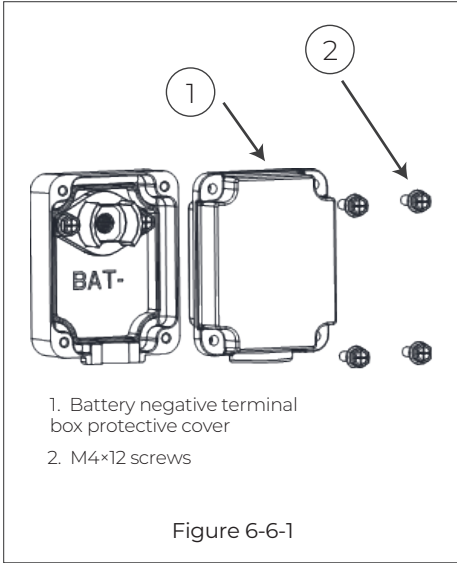

Figure 6-6-1

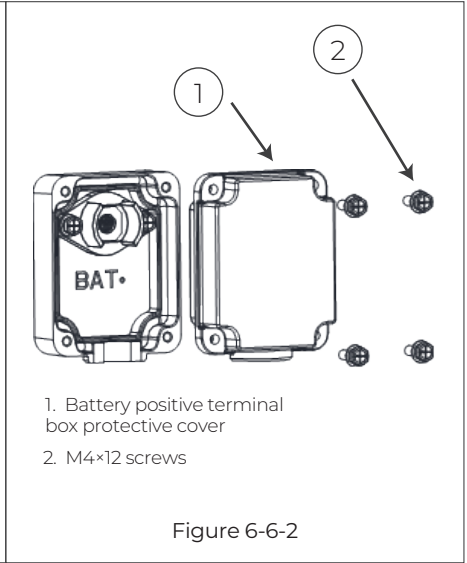

Figure 6-6-2

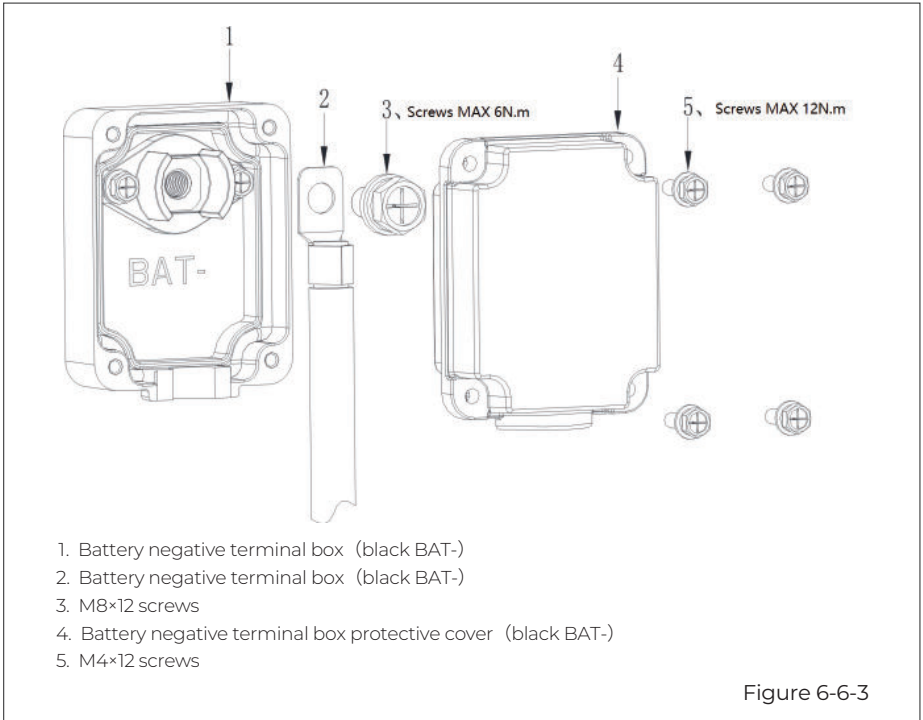

Figure 6-6-3

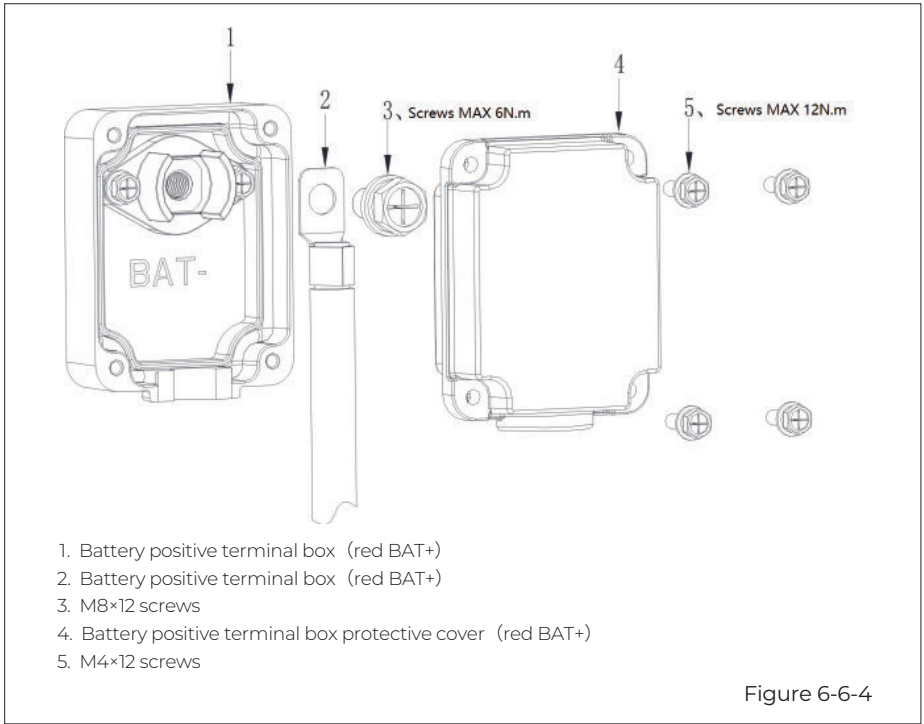

Figure 6-6 Battery positive and negative connection

6.8 Other interfaces

6.8.1 USB communication interface

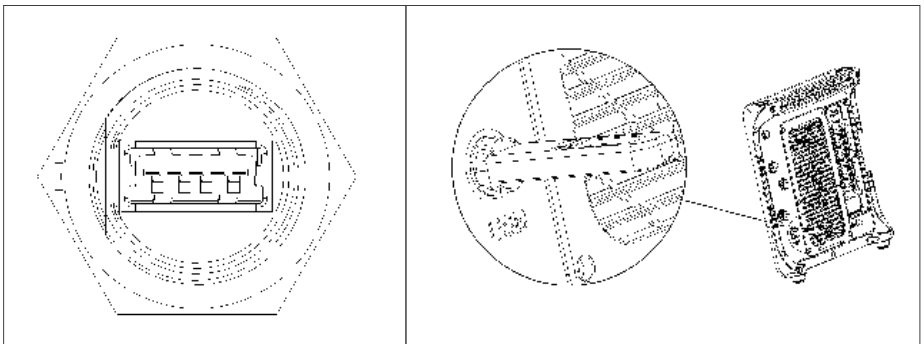



Figure 6-7 USB

U disk interface	U disk access (USB flash disk must be in FAT32 format, and the maximum memory is 32G)	For EP600 inverter firmware upgrade
------------------	---	-------------------------------------

Table 6-4 Interface Description

	Warning
	<p>Must be performed by an electrician with a professional technician certificate. Only for U disk access, not for USB charging.</p>

6.8.2 DRMs logical interface and dry contacts interface

The logical interface is applicable to the following safety standards: Australia (AS/NZS 4777), Europe (EN50549), Germany (VDE-AR-N 4105).

PIN	Signal Classification	Interface Definition	Interface Parameters
1	GEN COM	SPDT Relay Common port	External DC can not exceed 30Vdc/3A (Reserved for ignition of diesel generator)
2	GEN NC	SPDT relay normally closed output port	
3	GEN NO	SPDT relay normally opened output port	
4	INS GND	I/O output ground	Signal input/output ground
5	EXT IN	DRMs input	Signal input, active low (Connected to signal ground)
6	EXT OUT	I/O output	Signal output, active low

Table 6-5

Operation steps.

Step 1: Remove the unconnected end of the DRM's connector adapter counter-clockwise.

Step 2: Thread the extension cable into the connector shell and install the corresponding signal cable into the connector pins.

Step 3: Tighten the screws of the connector with a screwdriver.

Step 4: Gently pull the connection cable of 6 pins to determine whether the connection is tight;

Step 5: Tighten the connector shell and nut clockwise.

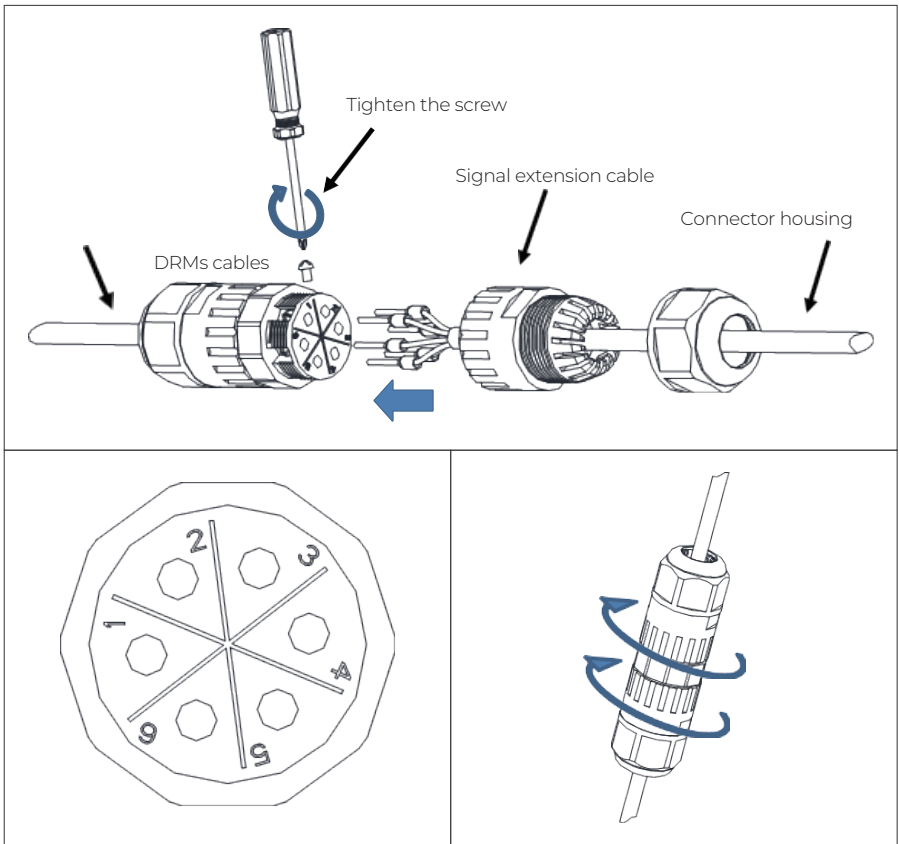

Figure 6-8 Logical Interface

6.8.3 Link Port 1 & 2 Interface Link Port 1、 2

Table 6-6

Interface	Interface function	Remark
Link Port 1	Connect the IOT controller	For details, please refer to 6.1 complete machine connection
Link Port 2	Connect the battery pack	

6.8.4 COM-Electricity Meter Communication Interface

For electricity meter communication:

Table 6-7 Interface Description

485 electricity meter communication port	Interface function	Wiring method
A (1)	A: RS485 differential signal +	Connect meter A2
B (1)	B: RS485 differential signal -	Connect meter B2

	Descriptions
	For details of the meter connection, please refer to the meter manual.

Operation steps.

Step 1: Remove the unconnected end of the COM connector adapter counter-clockwise.

Step 2: Thread the extension cable into the connector shell and install the corresponding signal cable into the connector pins.

Step 3: Tighten the screws of the connector with a screwdriver.

Step 4: Gently pull the connection cable of 2 pins to determine whether the connection is tight;

Step 5: Tighten the connector shell and nut clockwise.

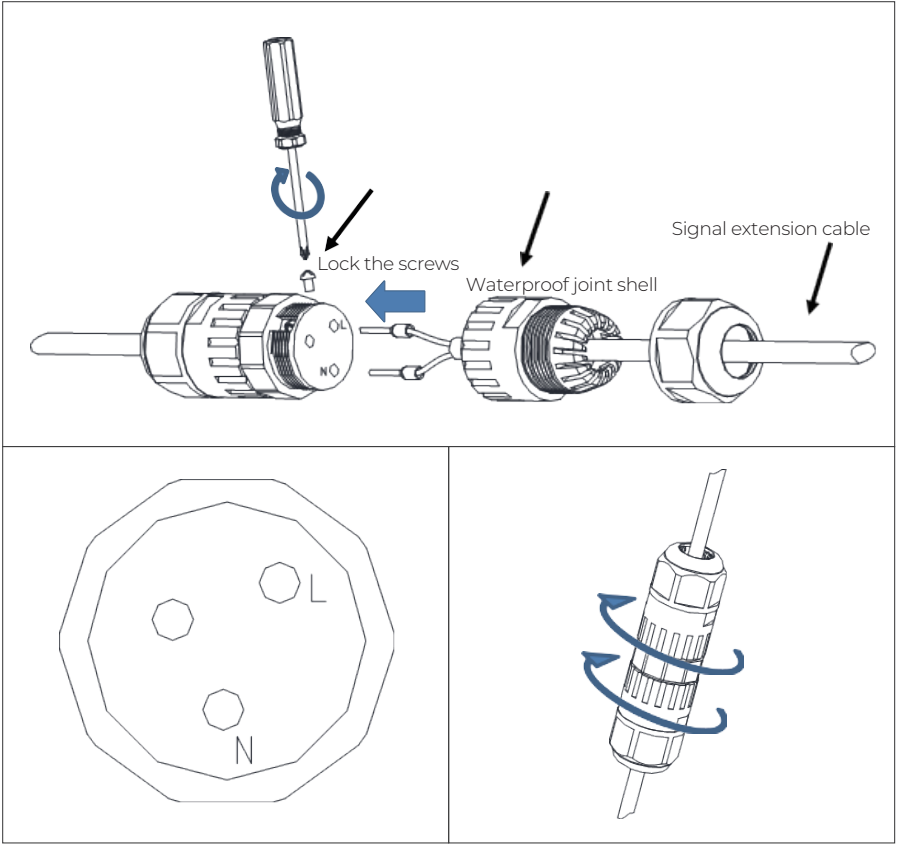

Figure 6-9 COM interface

6.8.5 CT-current transformer interface

Table 6-8

PIN	Define	Function	Remark
1	CT-R-(Black)	Negative pole of current transformer Output	For Connecting to current transformer of grid R phase
2	CT-R+(Red)	Positive pole of current transformer Output	

3	CT-S-(Black)	Negative pole of current transformer Output	For Connecting to current transformer of grid S phase
4	CT-S+(Red)	Positive pole of current transformer Output	
5	CT-T-(Black)	Negative pole of current transformer Output	For Connecting to current transformer of grid T phase
6	CT-T+(Red)	Positive pole of current transformer Output	

Operation steps.

Step 1: Remove the unconnected end of the CT connector adapter counterclockwise.

Step 2: Thread the extension cable into the connector shell and install the corresponding signal cable into the connector pins.

Step 3: Tighten the screws of the connector with a screwdriver.

Step 4: Gently pull the connection cable of 6 pins to determine whether the connection is tight;

Step 5: Tighten the connector shell and nut clockwise.

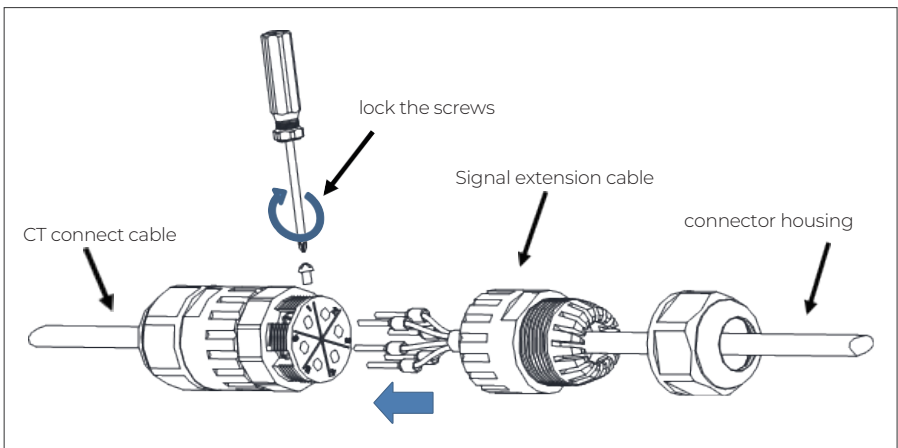

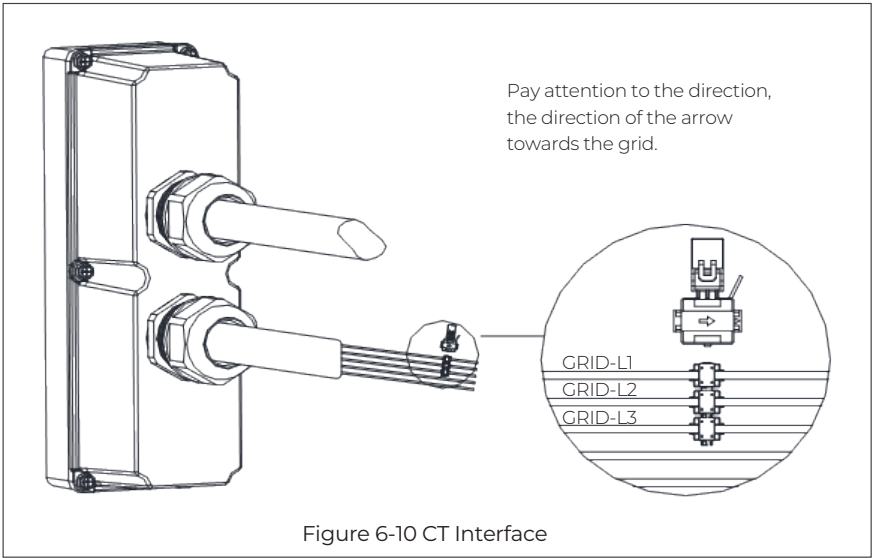
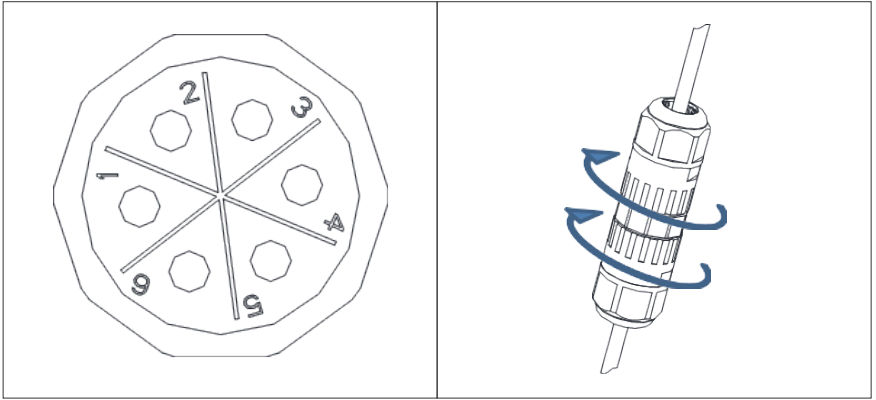



Figure 6-10 CT Interface

There are two methods to obtain grid-connected current information and prevent backflow when needed:

Method A	CT	Figure 6-11
Method B	Electricity Meter + CT	Figure 6-12

	Description
	The system with each phase current less than 100A can directly connect to CT or electricity meter; if the current exceeds 100A, only the meter can be used.
	Instruction
	The power, statistical power and other information displayed by AI? is only a regular reflection of the system, operation status, and this part of information should not be used as the basis for billing or judging the performance of this product.

Connect in the direction of CT, refer to the figure below, from the inverter to the grid:

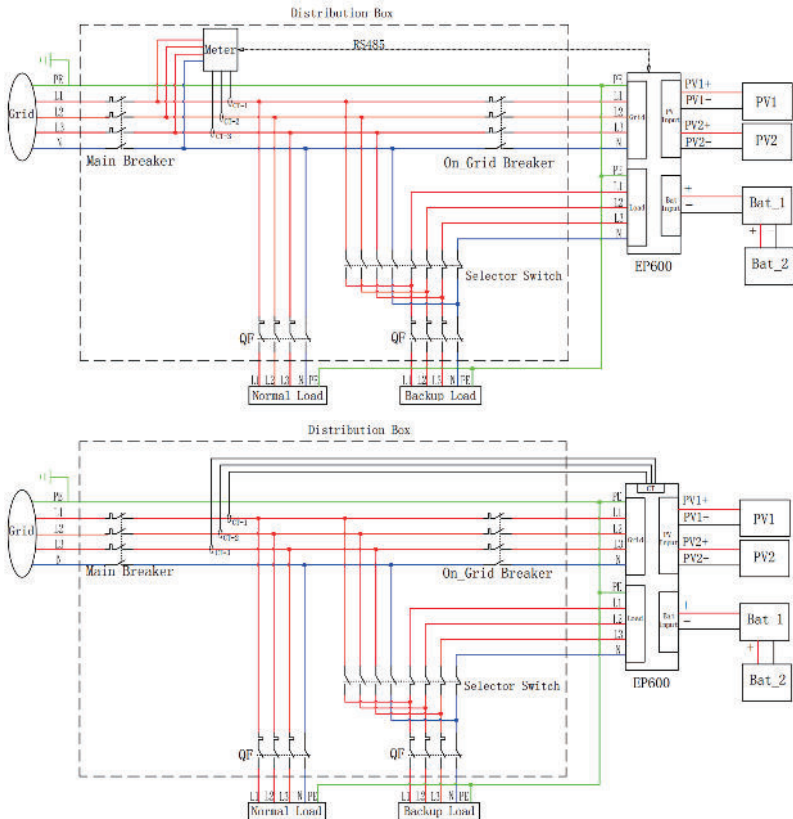

Figure 6-11 Electrical connection (method B: Electricity meter + CT)

6.9 B500 power on and power off

After installation:

- Check whether the power and communication cable are connected reliably;
- Check whether the battery pack and inverter are secure and stable;
- Move tools and parts away from the Energy Storage System;
- Push the circuit breaker handle of all battery packs up to the ON position
- Then press and hold the power button of any battery pack for 3 seconds until the green indicator on the button lights up (or turn on the PV switch of the inverter, or turn on the grid switch of the inverter);
- All connected battery packs will be fully activated and the indicator lights will be on

Note: If the indicator lights of some battery packs are not on, check the communication cable.

To turn off the battery pack, please follow the steps below:

- Turn off the PV switch of the inverter;
- Turn off the grid switch of the inverter;
- Press the power button of any battery pack until the green indicator light on the button starts to flash;
- The battery pack will enter the shutdown process, during which the indicator light will continue to flash;
- After the indicator light stops flashing and goes out, the shutdown process of the B500 is complete ;
- Finally, push the battery pack circuit breaker handle down to the OFF position.

6.10 Communication methods

The EP600 energy storage system is connected to the IOT controller, and the inverter information can be seen on the mobile APP through Bluetooth or WiFi. And remotely control the working mode of the inverter.

The working information of the system (power generation, alarm, and working status) can be uploaded to the server through WiFi network. Users can use the APP to view and control the device according to their needs, which requires registering an account and binding the device by scanning the QR code of EP600.

The IOT controller contain the following communication methods:

communication methods	Remark
Wi-Fi	Standard
Bluetooth	Standard

6.10.1 IoT Controller Introduction

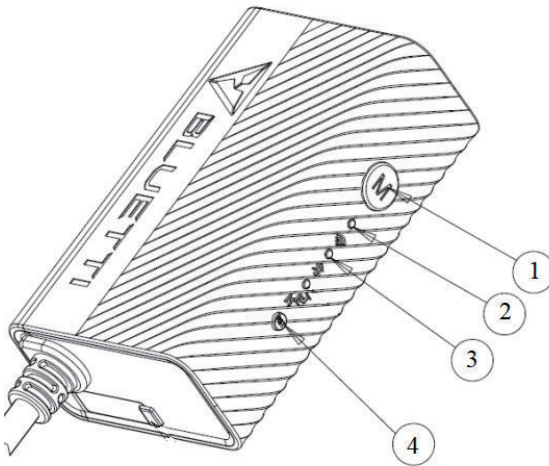

1. Menu Button.
To factory reset the controller, press and hold this button till all LED indicators flash.
2. WiFi Indicator.
Flash till the controller connects to WiFi.
3. Bluetooth Indicator.
Flash till the controller connects to Bluetooth.
4. Reboot Button.

Fig. 6.13

6.10.2 IoT Controller Installation

	Danger
	Avoid cables and pipes before drilling into the wall

- a. Drill 2 pilot holes in the wall. Please refer to the drill position and hole size shown in fig. 6-14-1 and fig. 6-14-2. The depth of hole is 26mm.
- b. Hammer the expansion wall plug in until it's flush with the wall. See fig. 6-14-3.
- c. Fix the mounting bracket onto the wall and use the Phillips screwdriver to fasten 2 self-tapping screws into the wall plugs. See fig. 6-14-4.
- d. Align the controller's buckle over the U-slot and push the controller downwards until it snaps in place. See fig. 6-14-5 and fig. 6-14-6.

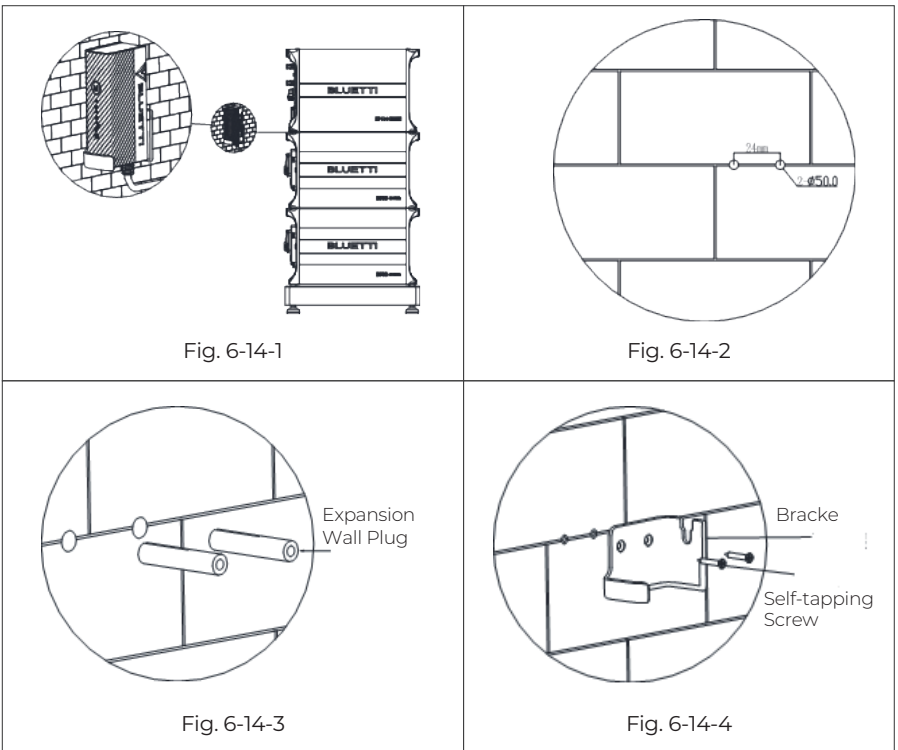

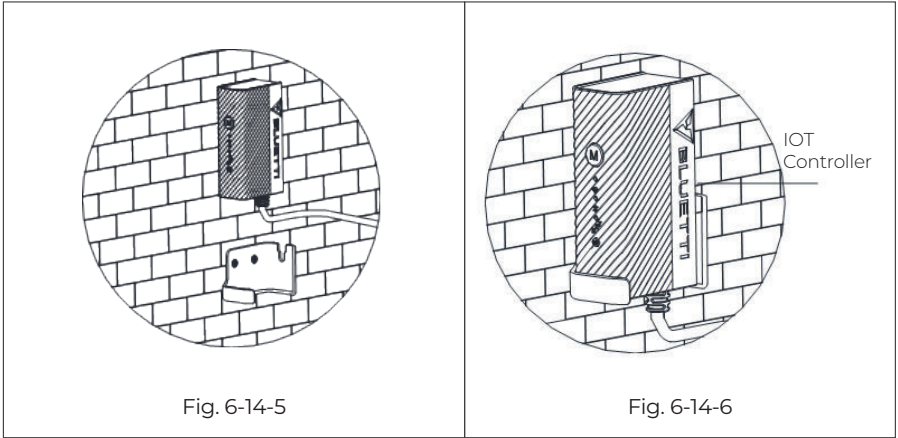

Fig. 6-14

6.10.3 Safety Instructions

- The IoT controller is ONLY applicable to BLUETTI products only.
- Do not keep the controller near heat sources or in high temperatures.
- Do not store the controller with flammable liquids, gases, or explosive materials.
- The inspection, testing, and maintenance should be performed by qualified personnel.

Warning

- Do not block or cover the openings of the controller. Keep it out of the reach of children.
- Use dry powder fire extinguisher in case of fire.

6.10.4 Connection and Operations



Fig. 6.15

- a. Plug the communication cable into EP600 Signal Port 1.
- b. Turn on EP600, and the IoT controller starts up automatically.
- c. Configure the controller in BLUETTI app.

Please refer to BLUETTI App Instructions for details.

6.11 Firmware Upgrade

6.11.1 Upgrade via USB Drive

EP600 inverter supports firmware upgrades via a USB drive to optimize its performance and avoid failures caused by firmware errors.

- a. Insert the USB drive into a USB port on your computer.
- b. Download the upgrade file, unzip and store it on the USB drive. Please contact BLUETTI customer service for latest upgrade files.
- c. Insert the drive into the USB port on EP600.
- d. Power on EP600.
- e. The firmware upgrade starts automatically once the upgrade files are detected.
- f. The buzzer beeps once after the firmware is updated successfully. Please unplug the USB drive, or EP600 will report a USB Format Error.
- g. Pair EP600 with BLUETTI app, then you can check the firmware version on the phone. If any of the following occurs, please try the solutions provided. If the symptom persists (for 5 times) , contact the BLUETTI support team, and we'll get back to you in 48 business hours.

Error Description	Solution
USB Upgrade Failed.	Please contact the BLUETTI support team.
USB Format Error.	1.Make sure the USB is formatted as FAT32 with no more than 32G in size. 2.Check if the upgrade files exist or expire. Please download the latest upgrade files.
Firmware version not updating or abnormal.	Please download the latest upgrade files. If the symptom persists, contact the BLUETTI support team.

6.11.2 OTA (Over-the-air) Upgrade

EP600 inverter also supports OTA upgrade. Connect it to the BLUETTI app and check for firmware updates. Please refer to BLUETTI App Instructions for detailed instructions.

7. System Check

7.1 Preliminary Check

Check the followings before first use.

- Confirm that all components of the system are installed according to specific requirements.
- Make sure the PV+/PV- and BAT+ and BAT- cables are connected with correct polarity and proper voltage.
- Switch off all AC and DC circuit breakers.
- Circuit breakers should be selected according to the requirements of this manual and local regulations.
- Make sure grid and load cables are held firmly in place.
- All safety signs and warning labels shall be firmly attached and clearly visible when needed.

7.2 Power On

- a. Switch on the DC circuit breaker on EP600.
- b. Switch on the DC circuit breakers on B500 battery packs.
- c. Switch on the AC circuit breakers on EP600 grid port.
- d. Switch on the AC circuit breakers on EP600 load port.
- e. When EP600 detects that the grid meets the requirements for grid connection under good light conditions, it starts to operate automatically. And you can turn on B500 under the same conditions. Please refer to B500 Startup and Shutdown (Section 6.9).
- f. Check the status of LED indicators or the system status displayed on BLUETTI app.

7.3 Power Off

	<p style="text-align: center;">Warning</p> <p>Wait at least 30 minutes after powering OFF the system before performing maintenance or inspections, as this may cause electric shock or burns.</p>
---	--

- a. Turn off the AC power on BLUETTI App.
- b. Switch off the AC circuit breakers on EP600 grid port and load port.
- c. Switch off EP600 PV switch.
- d. Press the power button on any B500 till the indicator on the button flashes green.
- e. The indicator continues to flash.
- f. When the indicator is off, B500 battery packs turn off.
- g. Switch off all B500 manual switches and the system powers off.

8. BLUETTI App

8.1 Introduction

BLUETTI app allows you to monitor and control the EP600 inverter system in the palm of your hand via Bluetooth or WiFi, with features like In-time Alarm, Error Message, Data Collection, Operation Status, Parameter Configuration, and Firmware Upgrade.

8.2 Download

Scan the QR code to download the BLUETTI app. Or get the app from App Store or Google Play.

Please visit <https://www.bluettipower.com> for details



8.3 Connection

EP600 inverter system connects to BLUETTI app via Bluetooth or WiFi.

Bluetooth Connection

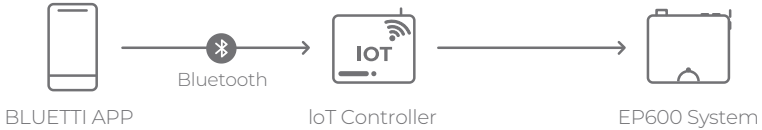

Fig. 8.1 Bluetooth Connection

WiFi Connection

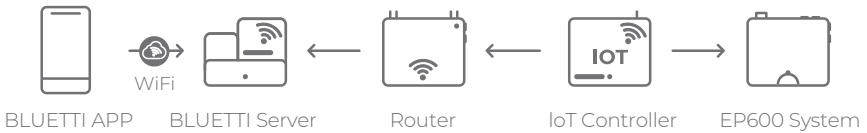

Fig. 8.2 WiFi Connection

Note:

- Supported operating systems: Android 6.0 or above, iOS 11.0 or above.
- Bluetooth is available on your phone.
- The router supports WiFi of IEEE 802.11 b/g/n, 2.4GHz.
- BLUETTI recommends a router with WPA or WPA2_PSK encryption. The EP600 system doesn't support enterprise encryption (commonly used on public WiFi networks that require user authentication, like airport hotspots) and WEP and WPA TKIP encryption.
- Pictures shown are for illustration purposes only. Actual UI may vary by BLUETTI app version.

9.Dispose of the Inverter

9.1 Remove the Inverter

When the inverter is no longer in use, it must be disposed of properly.

- a. Power off the system.
- b. Disconnect all electrical connections to the inverter, such as signal cable, DC input cable, power cable, AC input cable, grounding cable, etc.
- c. Remove the inverter and related parts.

9.2 End-of-life Management for the Inverter

When the inverter reaches the end of its lifespan, it must be safely and carefully disposed of by the provisions of local laws and regulations.

10.Troubleshooting

Table 9.1

Error Code	Error Description	Solution
1	PV input 1	Turn off the inverter and wait 30 minutes to restart up it. If the symptom persists, please contact the BLUETTI support team.
2		
3	BUS Undervoltage	
4		
5	Hardware BUS Overvoltage	
6		
7	Hardware Battery Overvoltage	
8	Hardware Inverter Overcurrent	
9		
10	Hardware LLC Input Overcurrent	
11		

12	Balanced Circuit Input Overcurrent	Turn off the inverter and wait 30 minutes to restart up it. If the symptom persists, please contact the BLUETTI support team.
13	Auxiliary Power Undervoltage	
14	DC Component Exception	
15	Relay Failure	
16	PV Connection Error	
17	PV1 Overcurrent	Turn off the inverter and wait 30 minutes to restart up it. If the symptom persists, please contact the BLUETTI support team.
18	PV2 Overcurrent	
19		
20	PV1 Voltage High	Check if the total voltage of solar panels exceeds the limit. Reduce the number of solar panels and the inverter resumes operation after calibration.
21	PV2 Voltage High	
22		
23	PV1 ISO Failure	Check the insulation resistor between solar array and grounding for a short circuit.
24	PV2 ISO Failure	
25		
26	Hardware PV1 Failure	
27	Hardware PV2 Failure	
28		
29	GFCI Hardware Circuit Failure	Turn off the inverter and wait 30 minutes to restart up it. If the symptom persists, please contact the BLUETTI support team.
30	GFCI Failure	Check if the AC output PE wire is grounded.
31	Phase Sequence Error	Check if the grid connection meets installation requirements.
32	Fan Failure	Check if the inverter fan operates well.
33	Zero Drift Anomaly	Turn off the inverter and wait 30 minutes to restart up it. If the symptom persists, please contact the BLUETTI support team.
34	Hardware Input Overcurrent	

35	DC Input Voltage Low	Check if the DC voltage is too low.
36	DC Input Voltage High	Check if the DC voltage is inconsistent with the battery specifications.
37	DC Input Overcurrent	
38	LLC Output Overvoltage	Turn off the inverter and wait 30 minutes to restart up it. If the symptom persists, please contact the BLUETTI support team.
39		
40	Inverter Overload	Check if the inverter is overloaded.
41		
42		
43	Inverter Output Failure	
44		
45		
46	Over Temperature Protection	
47	Hardware PVI Failure	Turn off the inverter and wait 30 minutes to restart up it. If the symptom persists, please contact the BLUETTI support team.
48		
49	DSP Communication Interrupted	Turn off the inverter and wait 30 minutes to restart up it. If the symptom persists, please contact the BLUETTI support team.
50	BMS Communication Interrupted	Turn off the inverter and wait 30 minutes to restart up it. If the symptom persists, please contact the BLUETTI support team.
51	IOT Communication Interrupted	
52	Zero Drift Anomaly-ARM	Turn off the inverter and wait 30 minutes to restart up it. If the symptom persists, please contact the BLUETTI support team.
53	RTC Read and Write Anomaly	
54	Inverter Leakage Current High	

55	Operating Ambient Temperature Anomaly	Please make sure use the system within specific temperature range. If the symptom persists, please contact the BLUETTI support team.
56	Temperature 1 Anomaly	
57	Temperature 2 Anomaly	
58	Temperature 3 Anomaly	
59	Temperature 4 Anomaly	
60	BMS Charge Protection	Check the details on BLUETTI app.
61	BMS Discharge Protection	
62	BMS System Failure	
63-64		
65	PV Voltage Too High	
66	LLC Output Voltage Low	
67-96		
97	Grid Voltage High	If it occurs occasionally, the grid may go through abnormal working conditions. The inverter recovers after the grid resumes. If it occurs many times, check if the grid voltage and frequency support the inverter input specifications. Check the inverter AC circuit breaker and connections. If the voltage and frequency are beyond the range, please contact the BLUETTI support team.
98	Grid Voltage Low	
99	Grid Over Frequency	
100	Grid Low Frequency	
101	Grid Oscillation	
102	Grid Loss	
103	PV1 Voltage Low	Check the PV setup. Solar panels may get a low voltage without proper working conditions.
104	PV2 Voltage Low	

105		
106	Generator Voltage Anomaly	
107	DSP_Debug CAN Communication Failure	
108	DSP_Debug RS485 Communication Failure	
109-128		
129	EEPROM Read and Write Anomaly	Please reconfigure the settings on BLUETTI app. If the symptom persists, please contact the BLUETTI support team.
130	Grid Voltage High-ARM	If it occurs many times, check if the grid voltage and frequency support the inverter input specifications. Check the inverter AC circuit breaker and connections. If the voltage and frequency are beyond the range, please contact the BLUETTI support team.
131	Grid Voltage Low-ARM	
132	Grid Over Frequency-ARM	
133	Grid Low Frequency-ARM	
134	USB Format Error	Please make sure the USB is formatted as FAT32 and its maximum memory is 32G. Check if the upgrade files exist or expire. Please download the latest upgrade files.
135	USB Upgrade Failure	Turn on the inverter again. If the symptom persists, please contact the BLUETTI support team.
136	USB Upgrade Failure	
137	USB Communication Anomaly	
138	USB No Upgrade File	
139	CT Connection Anomaly	
140-144		

11.Specifications

EP600

AC (Grid-tied)		
Item	Rating	Note
Rated Output Power	6000W	
Output Apparent Power	6000VA	
Wiring connection	L1/L2/L3/N/PE	
Rated Voltage	230V/400V	
Voltage Range	185V-285VAC×3	
Rated Output Current	8.7A×3	
Maximum Output Current	9.1A×3	
Input Frequency	50Hz	
Frequency Range	47.5Hz-51.5Hz	
Maximum Input Apparent Power	12000VA	Bypass + Charge
Maximum Input Current	18A	Bypass + Charge
Power Factor (PF)	1.0	0.9 Leading-0.9 Lagging
Current Total Harmonic Distortion (THD)	<3%	At Rated Power
On and Off-Grid Switching Time	<10ms	
Round-trip Efficiency	>82%(AC/AC)	Grid-Battery-AC Load
Protection	Anti-islanding Protection Residual Current Monitor Output Overcurrent Protection	